

SC650 Series Service Manual



SC650 50000628/50000629/50000630/50000631/
50000632/50000633/50000634/50000635/
50000636

NILFISK

English
09/2023 (Rev.01) Form No. 55943414

Table of Contents

| | |
|---|----|
| Table of Contents | i |
| 03 General Information | 4 |
| Machine General Description | 4 |
| Service Manual Purpose and Field of Application | 4 |
| Other Reference Manuals | 4 |
| Conventions | 5 |
| Service and Spare Parts | 5 |
| Serial Number Label | 5 |
| Safety | 6 |
| Visible Symbols on the Machine | 6 |
| Symbols | 6 |
| General Safety Instructions | 7 |
| Machine Lifting | 8 |
| Transporting The Machine | 8 |
| Technical Data | 9 |
| Maintenance Schedule | 11 |
| Machine Structure | 12 |
| Service and Diagnostic Equipment | 14 |
| Dimensions | 15 |
| 04 Control System | 17 |
| Functional Description | 17 |
| Block Diagram | 19 |
| Component Locations | 20 |
| Maintenance and Adjustments | 22 |
| Removal and Installation | 36 |
| Specifications | 39 |
| Shop Measurements | 44 |
| 10 Chassis System | 54 |
| Chassis (main parts) | 54 |
| 20 Drive system | 55 |
| Functional Description | 55 |
| Wiring Diagram | 55 |
| Component Locations | 56 |
| Maintenance and Adjustment | 58 |

| | |
|--------------------------------------|-----|
| Troubleshooting | 59 |
| Removal and Installation | 60 |
| Specifications..... | 63 |
| 24 Electrical System..... | 64 |
| Functional Description | 64 |
| Wiring Diagram (Lead-acid)..... | 65 |
| Wiring Diagram (Li-ion) | 66 |
| Component Locations (Lead-acid)..... | 67 |
| Component Locations (Li-ion) | 69 |
| Maintenance and Adjustments..... | 71 |
| Troubleshooting..... | 76 |
| Specifications..... | 76 |
| General Wiring Diagram | 77 |
| 30 Solution System | 81 |
| Functional Description..... | 81 |
| Wiring Diagram..... | 82 |
| Component Locations..... | 83 |
| Maintenance and Adjustment..... | 85 |
| Troubleshooting | 88 |
| Removal and Installation | 90 |
| Specifications..... | 93 |
| 34 Scrub System | 94 |
| Functional Description..... | 94 |
| Wiring Diagram..... | 95 |
| Component Locations..... | 96 |
| Maintenance and Adjustments | 98 |
| Troubleshooting | 100 |
| Removal and Installation..... | 101 |
| Specifications..... | 109 |
| 38 Squeegee System | 110 |
| Functional Description..... | 110 |
| Component Locations..... | 111 |
| Maintenance and Adjustment | 112 |
| Troubleshooting | 113 |
| Removal and Installation..... | 113 |

| | |
|---------------------------------|-----|
| Specifications | 113 |
| 40 Recovery System..... | 114 |
| Functional Description..... | 114 |
| Wiring Diagram | 114 |
| Component Locations..... | 115 |
| Maintenance and Adjustment..... | 117 |
| Troubleshooting | 119 |
| Removal and Installation..... | 120 |
| Specifications..... | 121 |

03 General Information

Machine General Description

The SC650 is a “walk-behind” industrial machine designed to wash and dry floors in one pass. The machine is powered by on-board batteries, models can be equipped with EcoFlex system. The machine can be equipped with disc brushes system or cylindrical brushes system, a controlled solution flow dosing system and a rear squeegee with rubber blades which vacuums and dries the floor.

Service Manual Purpose and Field of Application

The Service Manual is a technical resource intended to help service technicians when carrying out maintenance and repairs on the SC650, to guarantee the best cleaning performance and a long working life for the machine.

Please read this manual carefully before performing any maintenance and repair procedure on the machine.

Other Reference Manuals

| Model | Product Code | Instructions for use | Spare Parts List |
|------------------------------------|--------------|----------------------|------------------|
| SCRUBBER SC650 66D | 50000628 | 55943387 | 55943386 |
| SCRUBBER SC650 66D CHARGER ECOFLEX | 50000629 | | |
| SCRUBBER SC650 71D | 50000630 | | |
| SCRUBBER SC650 71D CHARGER ECOFLEX | 50000631 | | |
| SCRUBBER SC650 71C | 50000632 | | |
| SCRUBBER SC650 85D | 50000633 | | |
| SCRUBBER SC650 85D CHARGER ECOFLEX | 50000634 | | |
| SCRUBBER SC650 66D L | 50000635 | | |
| SCRUBBER SC650 85D L | 50000636 | | |

| Assembly Instructions | Instruction Code | Machine concerned |
|--------------------------------------|------------------|--------------------|
| SC650 LITHIUM-ION W/ICC STANDARD KIT | 55943396 | SC650 NILFISK/LIDL |
| ECOFLEX KIT NILFISK | 55943430 | SC650 NILFISK |
| ECOFLEX KIT LIDL | 55943431 | SC650 LIDL |
| USB PORT KIT | 55943432 | SC650 NILFISK/LIDL |
| MULTICON1 KIT | 55943433 | SC650 NILFISK/LIDL |
| CHARGER POWER KIT | 55943469 | SC650 NILFISK/LIDL |

These manuals are available at:

- Local Advance or Local Nilfisk Retailer
- Advance website: www.advance-us.com
- Nilfisk website: www.nilfisk.com

Conventions

Front, rear, left or right are intended with reference to the operator's position, in driving position.

Service and Spare Parts

Service and repairs must be performed only by authorized personnel or Advance/Nilfisk Service Centers. The authorized personnel must be trained directly by the manufacturer and use original spare parts and accessories. Customers can order spare parts according to the Model No. specified on the label.

(Apply Retailer label here)

Serial Number Label

The Model No. and Serial No. are shown on the nameplate on the machine. This information is needed when ordering repair parts. Use the space below to write down the machine identification data.

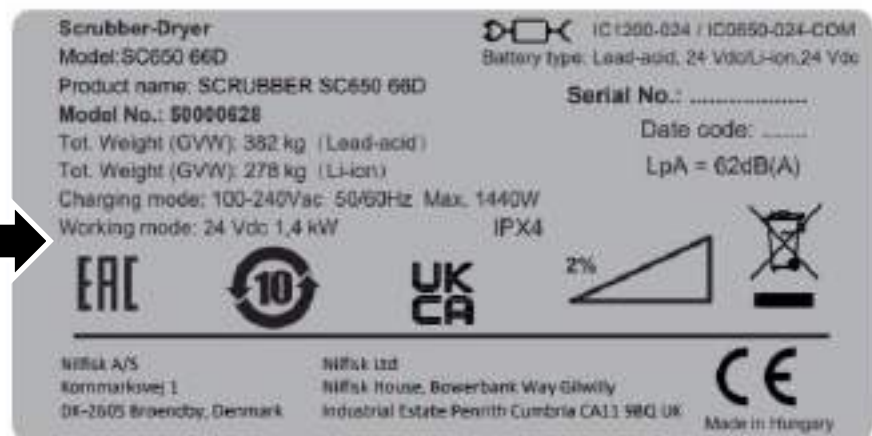

MODEL NUMBER _____

SERIAL NUMBER _____

Safety

The following symbols indicate potentially dangerous situations. Always read this information carefully and take all necessary precautions to safeguard people and property.

Visible Symbols on the Machine

**WARNING!**

Carefully read all the instructions before performing any operation on the machine.

**WARNING!**

Do not wash the machine with direct or pressurized water jets.

**WARNING!**

Do not use the machine on slopes with a gradient exceeding the specifications.

Symbols

It is important for you to read and understand this manual. The information it contains relates to protecting your safety and preventing problems. The symbols below are used to help you recognize this information.

**DANGER:**

Indicates a potentially hazardous situation which, if not avoided, could result in death or serious injury.

**WARNING:**

Indicates a potentially hazardous situation which, if not avoided, could result in minor or moderate injury.

**Caution:**

When used without the Safety Alert Symbol, indicates a potential situation which, if not avoided, could result in property or machine damage.

**Note:**

Indicates an important informational message.

General Safety Instructions

Specific warnings and cautions to inform about potential damages to people and machine are shown below.



DANGER!

- *Before performing any maintenance, repair, cleaning or replacement procedure disconnect the battery connector.*
- *This machine must be used by properly trained operators only. Children or disabled people cannot use this machine.*
- *When using lead (WET) batteries, keep sparks, flames and incandescent material away from batteries. During the normal operation explosive gases are released.*
- *Do not wear jewels when working near electrical components.*
- *Do not work under the lifted machine without supporting it with safety stands.*
- *Do not operate the machine near toxic, dangerous, flammable and/or explosive powders, liquids, or vapors: This machine is not suitable for collecting dangerous powders.*
- *When using lead (WET) batteries, battery charging produces highly explosive hydrogen gas. Keep the tank assembly open during battery charging and perform this procedure in well-ventilated areas and away from naked flames.*



WARNING!

- *Carefully read all the instructions before performing any maintenance/repair procedure.*
- *Before using the battery charger, ensure that frequency and voltage values, indicated on the machine serial number plate, match the electrical mains voltage.*
- *Do not pull or carry the machine by the battery charger cable and never use the battery charger cable as a handle. Do not close a door on the battery charger cable or pull the battery charger cable around sharp edges or corners. Do not run the machine on the battery charger cable.*
- *Keep the battery charger cable away from heated surfaces.*
- *Do not use the machine if the battery charger cable or plug is damaged. If the machine is not working as it should, has been damaged, left outdoors or dropped into water, return it to the Service Center.*
- *To reduce the risk of fire, electric shock, or injury, do not leave the machine unattended when it is plugged in. Before performing any maintenance procedure, disconnect the battery charger cable from the electrical mains.*
- *Do not smoke while charging the batteries.*
- *To avoid any unauthorized use of the machine, turn off the machine before leaving.*
- *Do not leave the machine unattended without being sure that it cannot move independently.*
- *Always protect the machine against the sun, rain and bad weather, both under operation and inactivity condition. Store the machine indoors, in a dry place: This machine must be used in dry conditions, it must not be used or kept outdoors in wet conditions.*
- *Before using the machine, close all doors and/or covers.*
- *Do not allow to be used as a toy. Close attention is necessary when used near children.*
- *Use only as shown in this Manual. Use only Nilfisk' s recommended accessories.*
- *Take all necessary precautions to prevent hair, jewels and loose clothes from being caught by the machine moving parts.*
- *Do not use the machine on slopes with a gradient exceeding the specifications.*
- *Do not use the machine in particularly dusty areas.*
- *While using this machine, take care not to cause damage to people or objects.*
- *Do not bump into shelves or scaffoldings, especially where there is a risk of falling objects.*
- *Do not lean liquid containers on the machine, use the relevant can holder.*
- *The machine working temperature must be between 0 C and +40 C.*
- *The machine storage temperature must be between 0 C and +40 C.*
- *The humidity must be between 30% and 95%.*

**WARNING!**

- When using floor cleaning detergents, follow the instructions on the labels of the detergent bottles.
- To handle floor cleaning detergents, wear suitable gloves and protections.
- Do not use the machine as a means of transport.
- Do not allow the brushes to operate while the machine is stationary to avoid damaging the floor.
- In case of fire, use a powder fire extinguisher, not a water one.
- Do not tamper with the machine safety guards and follow the ordinary maintenance instructions scrupulously.
- Do not allow any object to enter the openings. Do not use the machine if the openings are clogged. Always keep the openings free from dust, hairs and any other foreign material which could reduce the air flow.
- Do not remove or modify the plates affixed to the machine.
- When the machine is to be pushed for service reasons (missing or discharged batteries, etc.), the speed must not exceed 4 km/h.
- This machine cannot be used on roads or public streets.
- Pay attention during machine transportation when temperature is below freezing point. The water in the recovery tank or in the hoses could freeze and seriously damage the machine.
- Use brushes and pads supplied with the machine and those specified in the User Manual. Using other brushes or pads could reduce safety.
- In case of machine malfunctions, ensure that these are not due to lack of maintenance. Otherwise, request assistance from the authorized personnel or from an authorized Service Center.
- If the machine
 - does not work properly.
 - is damaged.
 - has water or foam leaks.
 - has been left outdoors exposed to bad weather conditions.
 - is wet or has been dropped into water.

turn it off immediately and contact the Nilfisk Service Center or a qualified technician.

- If parts must be replaced, require ORIGINAL spare parts from an Authorized Dealer or Retailer.
- To ensure machine proper and safe operation, the scheduled maintenance shown in the relevant chapter of this Manual, must be performed by the authorized personnel or by an authorized Service Center.
- Carefully read all the instructions before performing any maintenance/repair procedure.
- Do not wash the machine with direct or pressurized water jets, or with corrosive substances.
- The machine must be disposed of properly, because of the presence of toxic-harmful materials (batteries, etc.), which are subject to standards that require disposal in special centers (see Scrapping chapter).

Machine Lifting



Caution! Never work under a machine without safety stands or blocks to support the machine.

Transporting The Machine



Caution! Before transporting the machine on an open truck or trailer, make sure that:

- All covers are closed.
- The recovery tank and solution tank are empty.
- Batteries (if equipped) are disconnected.
- The machine is securely fastened in place on the transport.

Technical Data

General technical data

| Model | SC650 66D (2 brushes/pad- holders) | SC650 71D (2 brushes/pad- holders) | SC650 85D (2 brushes/pad- holders) | SC650 71C (2 cylindrical brushes) |
|--|--|--|--|---|
| Power DC | 24 V | | | |
| Rated power | 1,400 W | | | 1,800 W |
| IP protection class | IPX4 | | | |
| Machine height | 1,072 mm | | | |
| Solution/recovery tank capacity | 80 litres | | | |
| Solution flow 3 cl/meter +1 l/min | 1.27/ 2.55/ 5.1 cl/m 3.8 l/min | 1.37/ 2.75/ 5.5 cl/m 3.8 l/min | 1.62/ 3.25/ 6.5 cl/m 3.8 l/min | 1.37/ 2.75/ 5.5 cl/m 3.8 l/min |
| EcoFlex™ system detergent flow | 0.25% ÷ 3% | | | |
| Drive wheel diameter | 267 mm | | | |
| Castor diameter | 100 mm | | | |
| Drive wheel specific pressure on the floor | 0.45 N/mm ² | 0.45 N/mm ² | 0.48 N/mm ² | 0.48 N/mm ² |
| Castor specific pressure on the floor | 1.03 N/mm ² | 1.03 N/mm ² | 0.91 N/mm ² | 0.91 N/mm ² |
| Vacuum system motor power (rated) | 400 W | | | |
| Drive motor power (rated) | 200 W | | | |
| Max. speed | 5.6 km/h | | | |
| Gradeability | 2% (1) | | | |
| Sound pressure level/silent mode (ISO 11201, ISO 4871) (LpA) | 65/63 ± 3 dB(A) | 66/64 ± 3 dB(A) | 67/65 ± 3 dB(A) | 70/69 ± 3 dB(A) |
| Vibration level at the operator's arms (ISO 5349-1) | < 2.5 m/s ² | | | |
| Battery compartment size (width x length x height) | 375 x 355 x 615 mm | | | |
| Vacuum max (silent mode) | 12.2/9.1 KPa | | | |
| On-Board Charger 50/60 Hz | 24V/25A | | | |
| Min. aisle turn | 192 mm | 203 mm | 245 mm | 242 mm |
| Average consumed power | 866 W | 1,079 W | 1,141 W | 1,004 W |
| Packing dimensions (L x W x H) | 1580x760x1251 mm | 1640x910x1276 mm | | |

(*): Optional

Technical data for machines with brush/pad-holder deck

| Model | SC650 66D (2 brushes/pad- holders) | SC650 71D (2 brushes/pad- holders) | SC650 85D (2 brushes/pad- holders) |
|---|--|--|--|
| Cleaning width | 660 mm | 710 mm | 837 mm |
| Brush /Pad diameter | 330 mm | 355 mm | 430 mm |
| Deck right/left offset | 35/35 mm | 75/75 mm | 132/132 mm |
| Brush distance from the floor (when lifted) | 125 mm | | |
| Squeegee width | 890 mm | | 1,040 mm |
| Machine maximum length | 1,500 mm | | 1,574 mm |
| Machine width without squeegee | 748 mm | | 860 mm |
| Weight without batteries and with empty tanks | 138 kg | 139 kg | 145 kg |
| Maximum weight with batteries (maximum capacity) and full tanks | 441 kg | 442 kg | 448 kg |
| Shipping Weight | 186 kg | 200 kg | 204 kg |
| Gross Vehicle Weight (GVW) | 346 kg | 347 kg | 353 kg |
| Brush motor power (rated) | 2 x 400 W | | |
| Brush speed | 220 rpm | | |
| Brush/pad-holder pressure with extra-pressure function turned off | 21 kg | 22 kg | 31 kg |
| Brush/pad-holder pressure with extra-pressure function turned on | 32 kg | 35 kg | 44 kg |

(*) Optional model

Technical data for machines with cylindrical brush deck

| Model | SC650 71C (2 cylindrical brushes) |
|---|---|
| Cleaning width | 703 mm |
| Cylindrical brush size (diameter x length) | 145 x 690 mm |
| Deck right/left offset | 91/91 mm |
| Cylindrical brush deck distance from the floor (when lifted) | 60 mm |
| Squeegee width | 890 mm |
| Machine maximum length | 1,472 mm |
| Machine width without squeegee | 785 mm |
| Weight without batteries and with empty tanks | 143 kg |
| Maximum weight with batteries (maximum capacity) and full tanks | 446 kg |
| Shipping Weight | 207 kg |
| Gross Vehicle Weight (GVW) | 351 kg |
| Brush motor power | 2 x 600 W |
| Cylindrical brush speed | 613 rpm |
| Cylindrical brush pressure | 36 kg |

Maintenance Schedule

The lifespan of the machine and its maximum operating safety are ensured by correct and regular maintenance.



Warning! *Maintenance procedures must be performed after the machine is turned off and the battery charger cable is disconnected. In addition, carefully read the instructions in the Safety chapter before performing any maintenance procedure.*

Scheduled Maintenance Table

| Procedure | Daily, after use | Weekly | Every 6 months | Annually |
|--|------------------|--------|----------------|----------|
| Battery charging | | | | |
| Squeegee cleaning | | | | |
| Brush/pad-holder cleaning | | | | |
| Recovery tank and debris tray cleaning | | | | |
| Tank sealing strip inspection | | | | |
| Float ball filter cleaning | | | | |
| Squeegee blade check or replacement | | | | |
| Solution filter cleaning | | | | |
| Vacuum system motor filter cleaning | | | | |
| WET battery fluid level check | | | | |
| EcoFlex system cleaning and draining (optional) | | | | |
| Fasteners tightness inspection | | | (1) | |
| Check and adjustment of driving belts between motors and cylindrical brushes (SC650 71C) | | | (1) | |
| Brush motor carbon brush check or replacement | | | | (2) |
| Vacuum motor carbon brush check or replacement | | | | (2) |
| Drive motor carbon brush check or replacement | | | | (2) |

1. Also perform this inspection after the initial 10 hours of new machine usage.
2. Must be done by Service Center authorized by our company.

Machine Structure

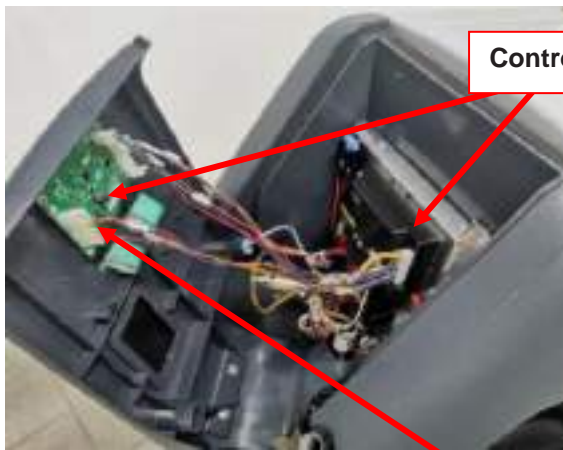

Chassis System

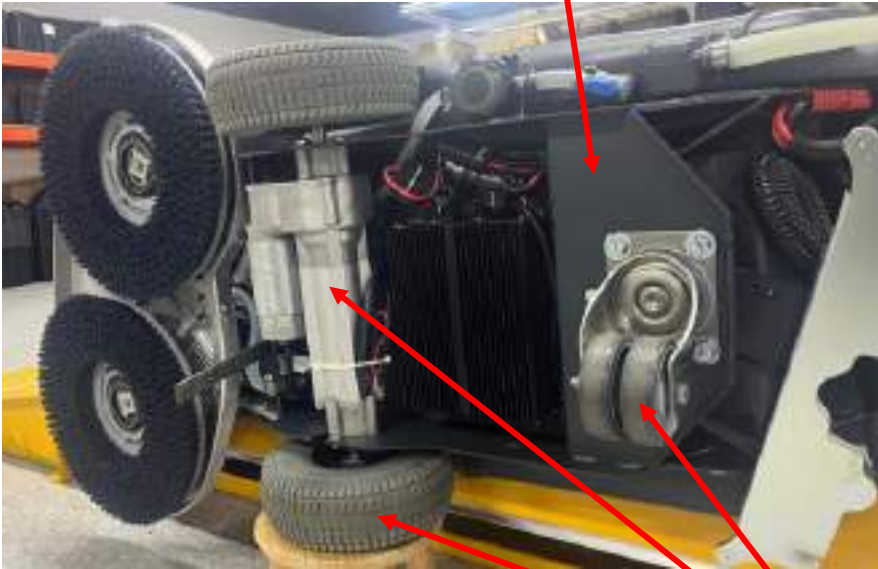

Drive System

Service and Diagnostic Equipment

Besides a complete set of standard tools, the following instruments are necessary to perform quick check and repairs on machines:

- Laptop computer charged with the current version of EzParts, Adobe Reader and (if possible) Internet connection.
- Digital Voltmeter (DVM)
- Amp clamp with possibility of making DC measurements.
- Hydrometer
- Battery charge tester to check 24 V batteries.
- Static control wrist strap
- Dynamometric wrench set.
- A copy of the User Manual and Spare Parts List of the machine to be serviced (provided with the machine or available at www.advance-us.com or other Nilfisk websites).

The following equipment is also available at Nilfisk or Advance Centers:

- Vacuum water lift gauge, P/N 56205281

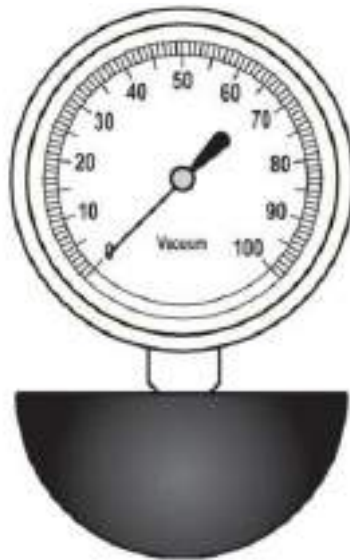

Dimensions

SC650 66D DIMENSIONS

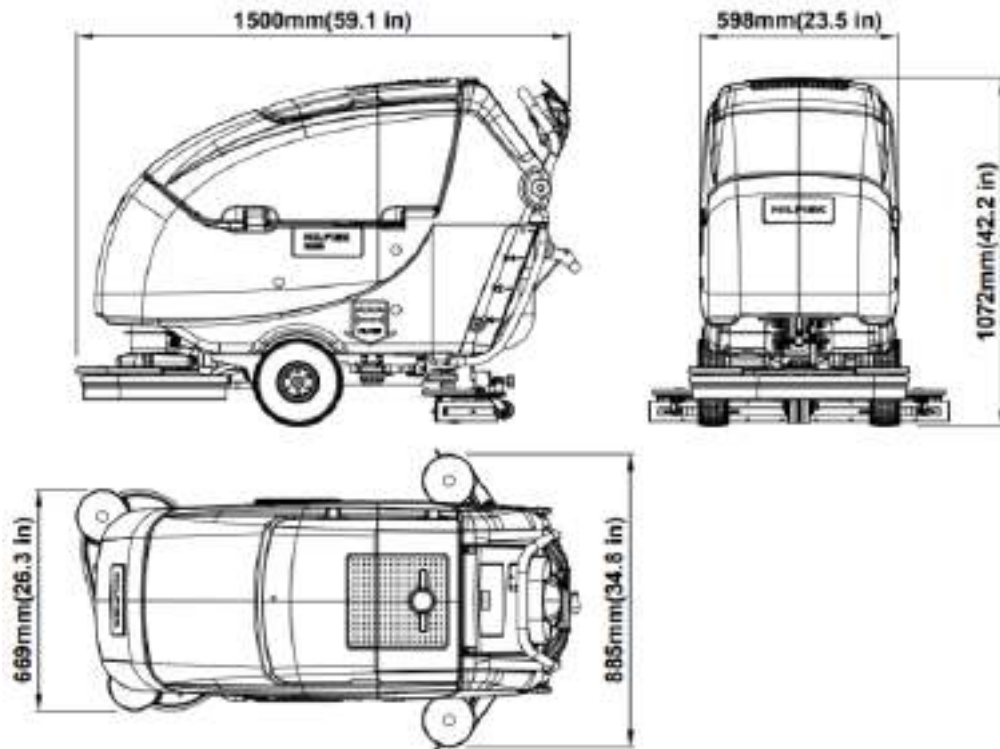

SC650 71D DIMENSIONS

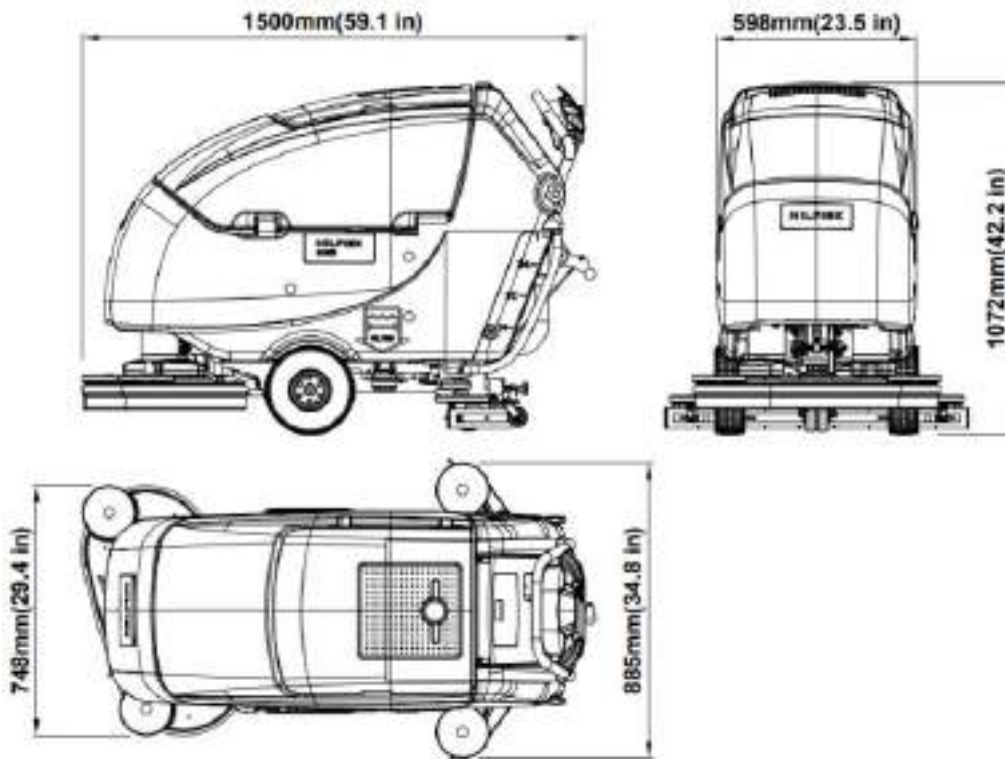

SC650 85D DIMENSIONS

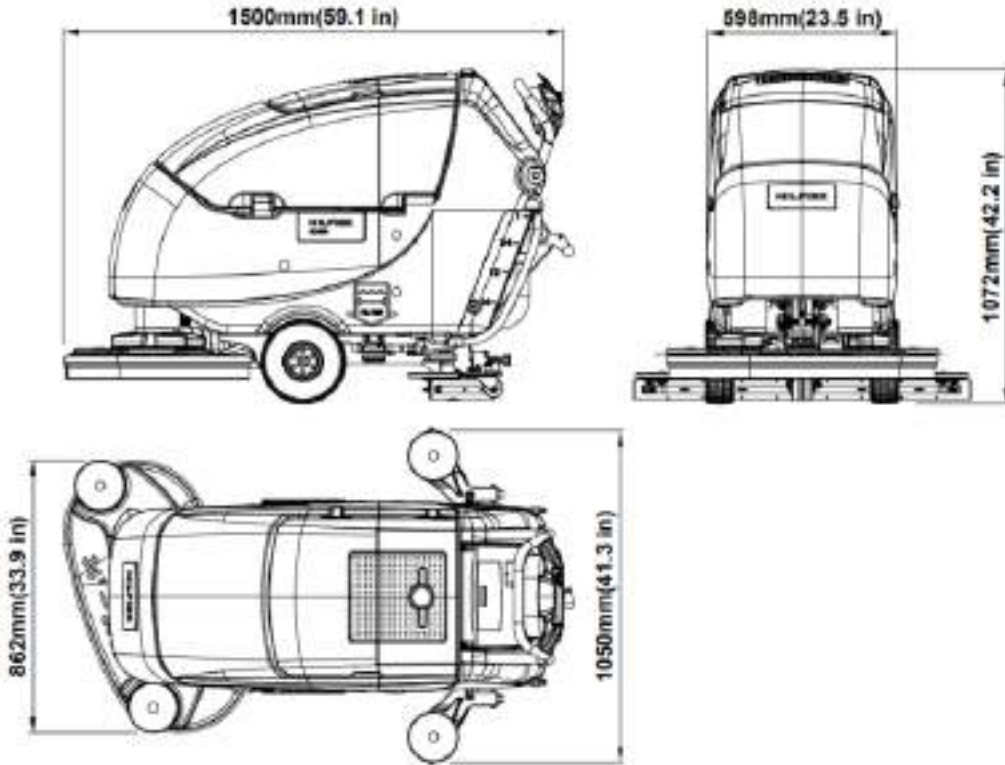

SC650 71C DIMENSIONS

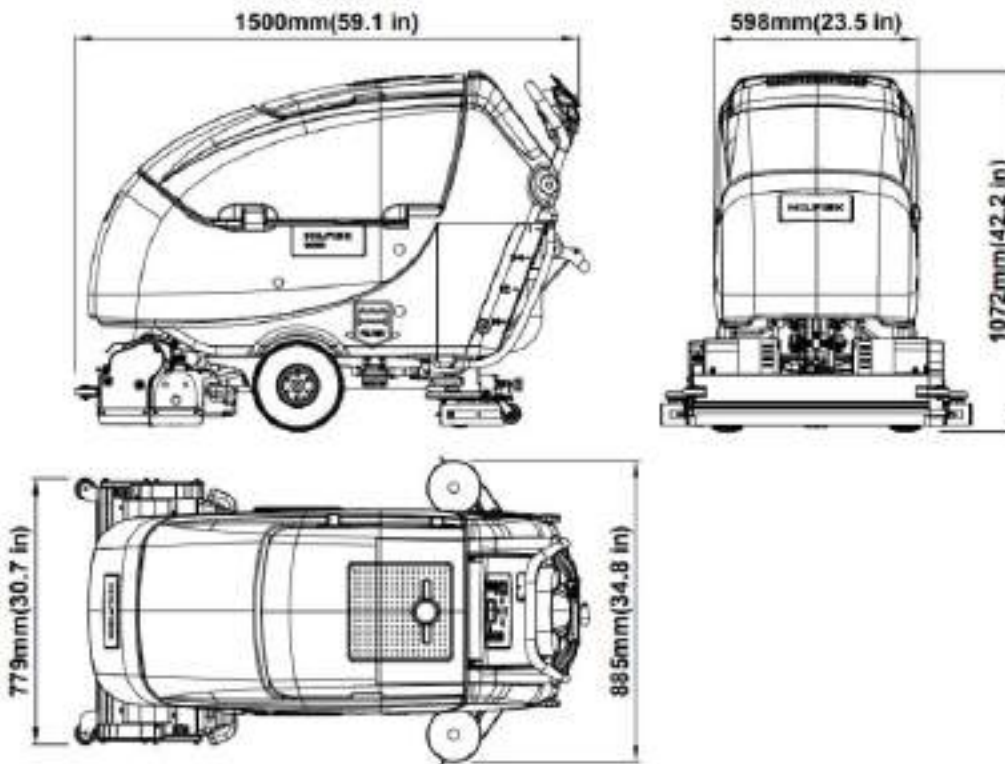

04 Control System

Functional Description

Product No.: 50000628, 50000629, 50000630, 50000631, 50000633, 50000634, 50000635, 50000636

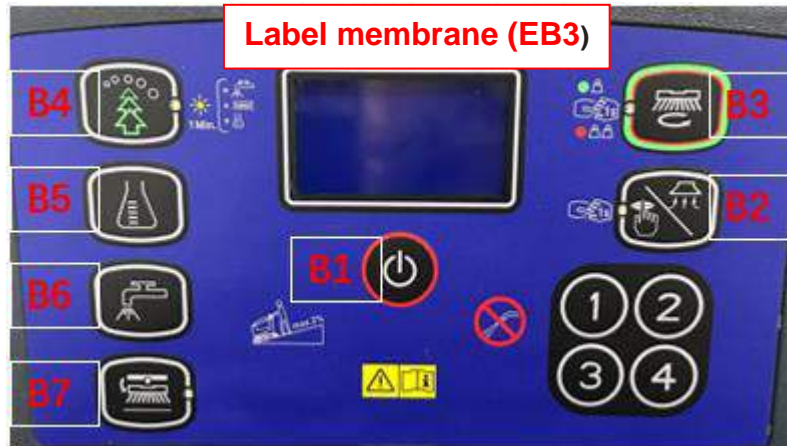

Product No.: 50000632

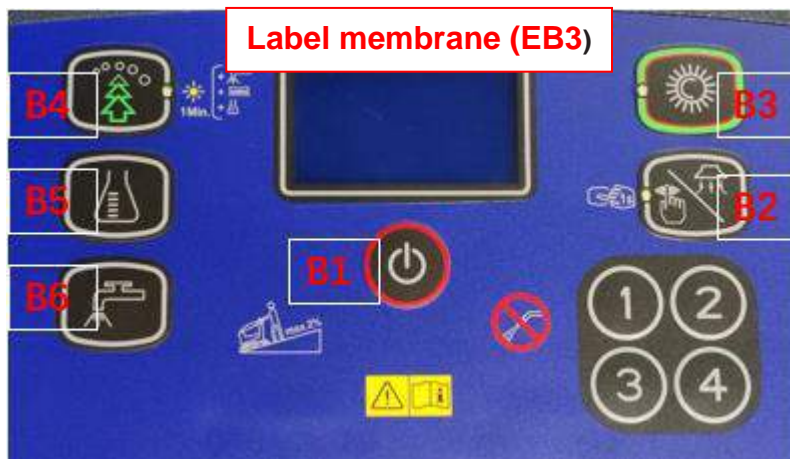

The machine utilizes a Label membrane (EB3) which represents the user interface to turn on various machine functions and a Main machine controller (EB1) and a UI controller (EB2) to control outputs. When Label membrane (EB3) receives inputs from operator, it activates various components and functions accordingly.

Press the power switch button (B1) on Label membrane (EB3) to turn on/off the machine. After that, Press the one-touch button (B3) on Label membrane (EB3) to activate/disable the function of the vacuum motor (M2) and actuator motor (M6). Then, hold the one-touch button (B3) for 1 second, the function of extra pressure for brush will be activated. Press the vacuum button (B2) on Label membrane (EB3) to turn on/off the vacuum motor (M2). Press the vacuum button (B2) for 1 second to switch between normal mode and silent mode. Press the solution flow switch (B6) and detergent flow switch (B5) on Label membrane (EB3), the solution flow and detergent flow will increase/decrease accordingly.

The EcoFlex system switch (B4) can only be effective when the one-touch button (B3) be activated. Once the EcoFlex system switch (B4) is pressed, the solution flow and detergent flow, as well as the brush pressure, are increased by one if their values have not been max. This function will last for 1 minute and then return to normal.

When the actuator motor (M6) is in the original position, press the brush/pad-holder release switch (B7) to release the brush via brush motor.

The machine utilizes Multicon1 module to send the necessary information to the user. And the machine utilizes USB socket to provide 5V/1A and 5V/2A DC power for the operator.

The Main machine controller (EB1) manages and drives the following components directly:

- Drive motor (M3)
- Vacuum motor (M2)
- Actuator motor (M6)
- Brush motors (M1)
- Solution flow solenoid valve (EV1)
- Water Pump (M4)
- Detergent pump (M5)

The UI controller (EB2) manages and drives the following components directly:

- Li-ion battery (LI-BAT)
- Multicon1
- Detergent level sensor (DS)
- Li-ion battery charger (LI-CH)
- USB socket (USB)

For the machine with lead acid battery, the on-board battery charger for lead acid battery which also uses a proprietary serial protocol to communicate with the UI Controller (EB2), to display its operating status (charging phase) to the operator on the UI Controller (EB2).

For the machine with Li-ion battery, the on-board battery charger for Li-ion battery which also uses Can bus protocol to communicate with the UI Controller (EB2), to display its operating status (charging phase) to the operator on the UI Controller (EB2).

Block Diagram

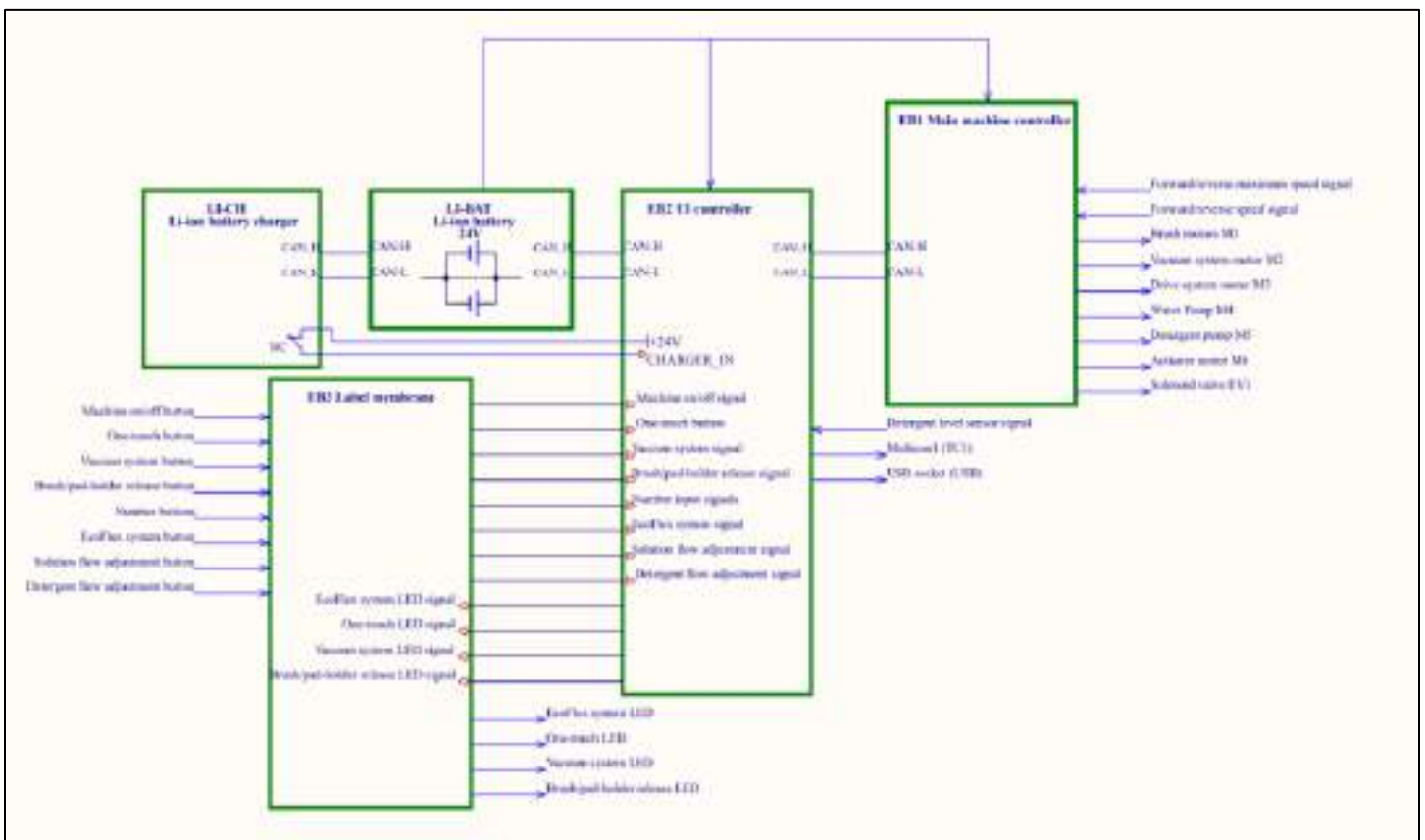
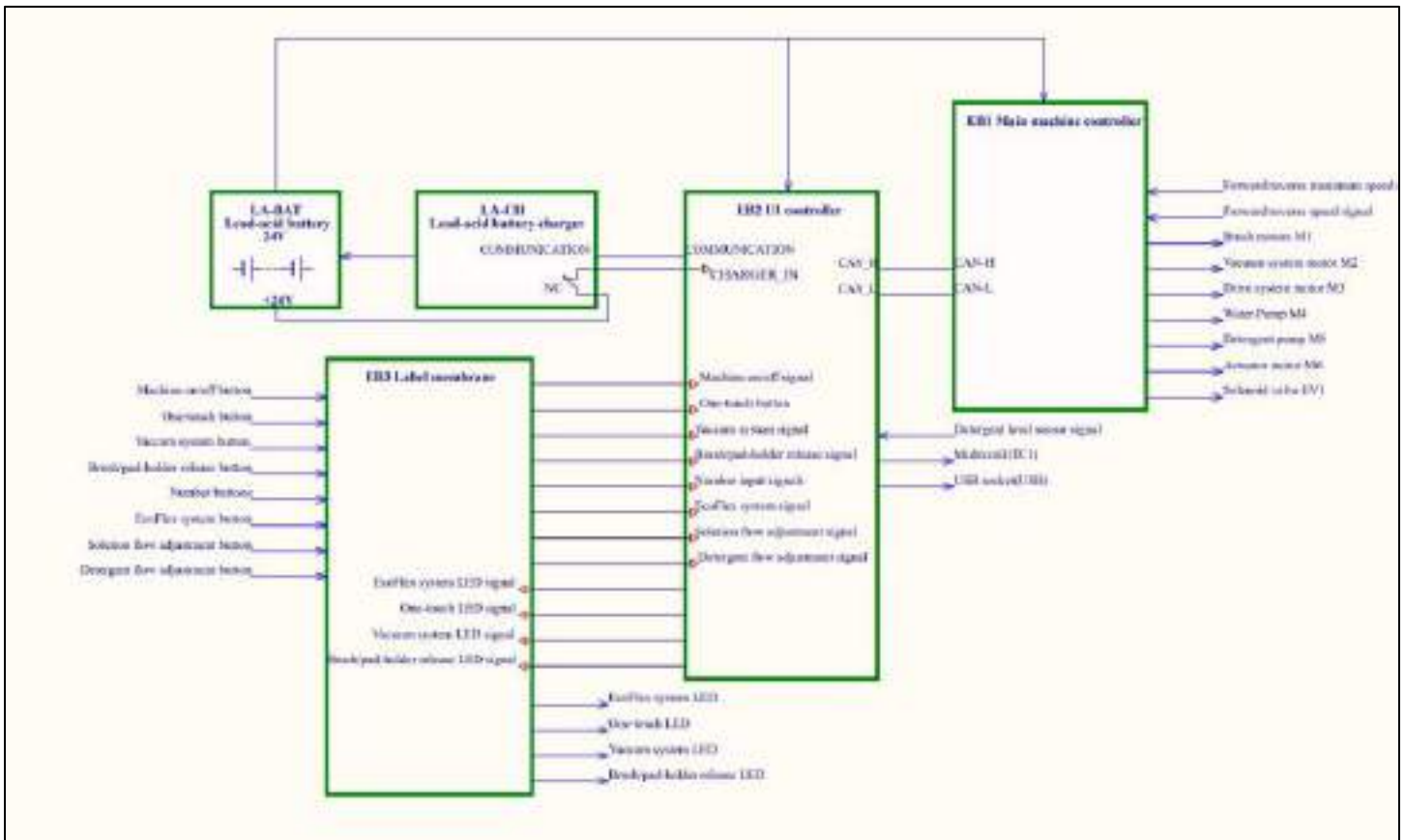

Component Locations

- Main machine controller (EB1)
- UI controller (EB2)
- Label membrane (EB3)
- Multicon1
- USB socket (USB)

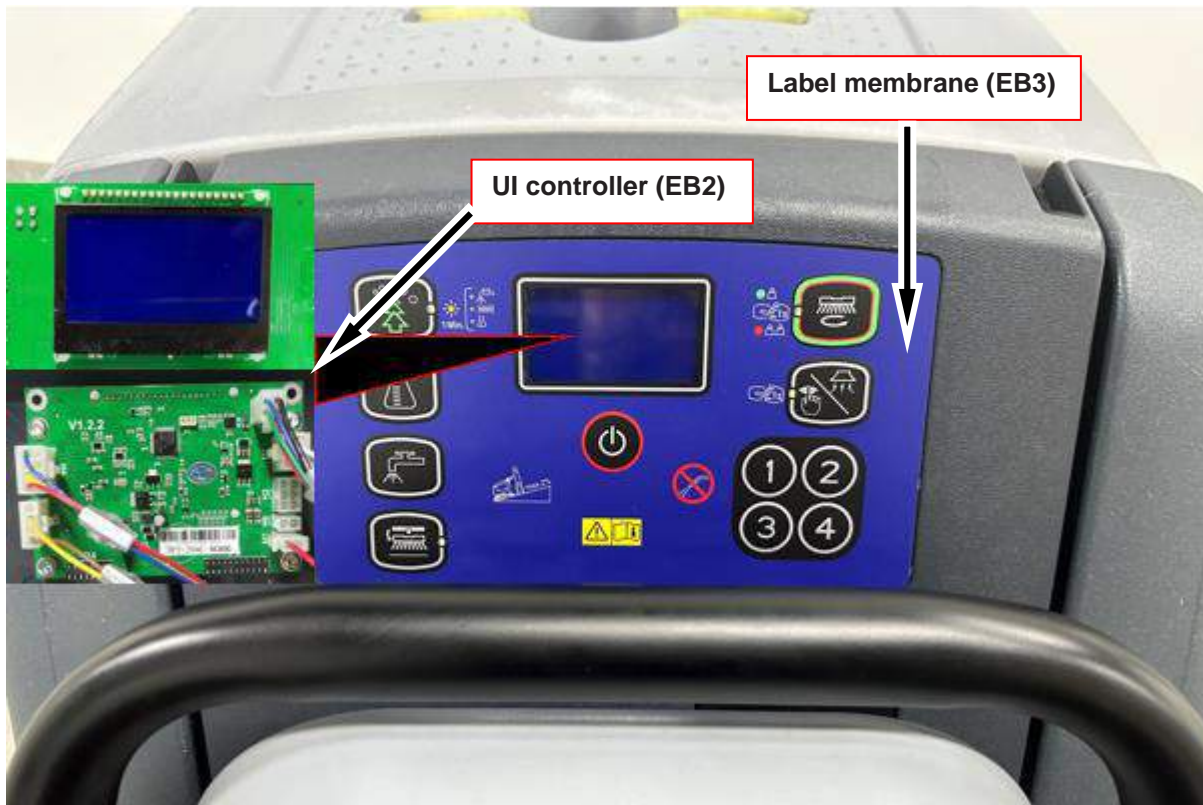
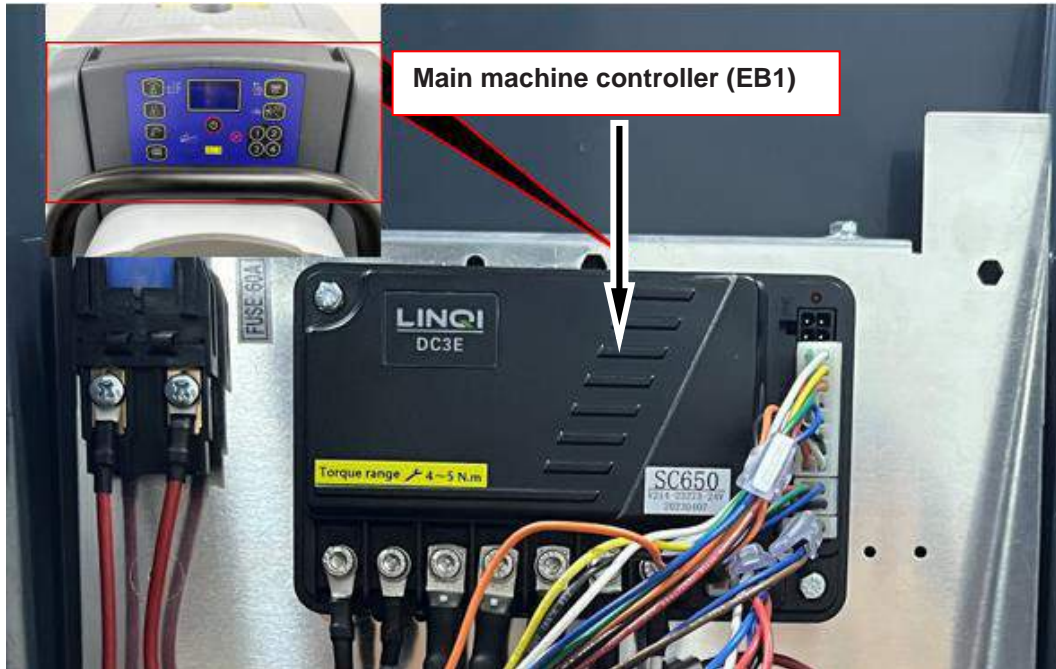



Maintenance and Adjustments

Alarm Codes

Main Machine Controller (EB1) and UI Controller (EB2) Alarm Codes

The Main machine controller and the UI Controller indicate a series of alarms in case of malfunction of one or more systems, and in case of abnormal conditions detected in the input signals.

The alarms are shown on the display in the following format: ALARM <XX> <DESCRIPTION>



| General alarms | | | | |
|---|--|--|------------------|---|
| Alarm code ----- Description | Meaning | Condition | Effect | Service Suggestions |
| E00 ----- PRECHARGE ERROR | Pre-charge error | 1. Short circuit on controller output. 2. Controller damaged. | Function blocked | 1. Remove the connectors of the main controller EB1 one by one to find out location of the short circuit. 2. Remove all the connectors connected to the main controller EB1, if the problem still exists, replace the main controller EB1. |
| E01 ----- BAT. OVERVOLTAGE | Excessive battery voltage | Battery voltage over 34V | Function blocked | Check the voltage of the installed batteries and that the terminals are correctly tightened. |
| E02 ----- BAT. UNDERVOLTAGE | Low battery voltage | Battery voltage under 12V | Function blocked | Check the battery voltage under no-load conditions and under load. Replace the faulty battery/batteries if necessary. |
| E03 ----- 12V HIGH ERROR | 12V power supply high inside the main controller | Controller damaged | Function blocked | Replace the main controller EB1. |
| E04 ----- 12V LOW ERROR | 12V power supply low inside the main controller | Controller damaged | Function blocked | Replace the main controller EB1. |
| E05 ----- RELAY FAILURE | Relay fault inside the main controller | 1. Abnormal cable connection 2. Controller damaged | Function blocked | 1. Check the cable connection. 2. If the problem still exists, replace the main controller EB1. |

| General alarms | | | | |
|--|---|--|--|--|
| <i>Alarm code</i> ----- <i>Description</i> | <i>Meaning</i> | <i>Condition</i> | <i>Effect</i> | <i>Service Suggestions</i> |
| E06 ----- NTC ERROR | Temperature sensor NTC failure inside the main controller | Temperature sensor NTC failure detected | If it is the NTC error of drive system, drive motor current is limited to 40A. If it is the NTC error of brush system, brush motor current is limited to 35A. If it is the NTC error of vacuum system, vacuum current is limited to 25A. | Replace the controller EB1. |
| E07 ----- OVER TEMP ERROR | Overtemperature inside the main controller | The internal temperature of the main controller is over 75degC | Output current is limited when the internal temperature of the main controller is over 75degC. The motors stop working when internal temperature of the main controller is over 85degC. | Turn off the machine to cool down the main controller. The error will disappear when the temperature of the main controller drops to 75degC. |
| E08 ----- TRACTION MOS SHORT ERR | Short circuit on the traction motor drive MOSFET | MOSFET short circuit | Function blocked | 1. Check that there are no short circuits in the traction motor wiring. 2. Replace the controller EB1. |
| E09 ----- BRUSH MOS SHORT ERR | Short circuit on the brush motor drive MOSFET | MOSFET short circuit | Function blocked | 1. Check that there are no short circuits in the brush motor wiring. 2. Replace the controller EB1. |
| E10 ----- VACUUM MOS SHORT ERR | Short circuit on the vacuum motor drive MOSFET | MOSFET short circuit | Function blocked | 1. Check that there are no short circuits in the vacuum motor wiring. 2. Replace the controller EB1. |
| E11 ----- ACT. MOS SHORT ERR | Short circuit on the actuator motor drive MOSFET | MOSFET short circuit | Function blocked | 1. Check that there are no short circuits in the actuator motor wiring. 2. Replace the controller EB1. |

| General alarms | | | | |
|--|--|--|---------------------------|--|
| <i>Alarm code</i> ----- <i>Description</i> | <i>Meaning</i> | <i>Condition</i> | <i>Effect</i> | <i>Service Suggestions</i> |
| E13 ----- TRACTION SHORT CIRCUIT | short circuit on traction motor | short circuit | Function blocked. | 1. Check that there are no short circuits in the traction wiring. 2. If alarm still exists, replace the controller EB1. |
| E14 ----- TRACTION OVERCURRENT | Traction motor amperometric protection. | Drive motor current draw greater than the parameter "INOM" for more than the parameter "TMAX". | Drive blocked. | Check the current draw of the drive motor. (This should remain 5-12amps during operation). |
| E15 ----- BRUSH OPEN CIRCUIT | Open circuit on brush motor | open circuit | Brush motor blocked | Check that there are no open circuits in the brush motor wiring. |
| E16 ----- BRUSH SHORT CIRCUIT | Short circuit on brush motor | short circuit | Function blocked. | 1. Check that there are no short circuits in the brush wiring. 2. If alarm still exists, replace the controller EB1. |
| E17 ----- BRUSH OVERCURRENT | Brush motor amperometric protection | The motor current is greater than the value of the parameter VS1 /VS2. | Brush motor output stops. | Check the current draw of the brush motor. It should remain below the value set in the parameter "VS1" "VS2" during operation. |
| E18 ----- VACUUM OPEN CIRCUIT | Open circuit on vacuum motor | Open circuit | Vacuum motor blocked | Check that there are no open circuits in the vacuum motor wiring. |
| E19 ----- VACUUM SHORT CIRCUIT | Short circuit on brush motor | Short circuit | Vacuum system blocked. | 1. Check that there are no short circuits in the vacuum wiring. 2. if alarm still exists, replace the controller EB1. |
| E20 ----- VACUUM OVERCURRENT | VACUUM SYSTEM amperometric protection. | The current draw of the vacuum motor is greater than 30A for over 10seconds. | Vacuum system blocked. | 1. Check for any debris in the vacuum motor. 2. Check that the motor rotor turns freely. 3. Replace the vacuum motor if necessary. |
| E22 ----- ACT. SHORT CIRCUIT | Short circuit on actuator moto | Short circuit | Function blocked. | 1. Check that there are no short circuits in the actuator wiring. 2. If alarm still exists, replace the controller EB1 |
| E23 ----- ACT. OVERCURRENT | Actuator SYSTEM amperometric protection. | The current draw of the actuator motor is greater than 7A for over 1 seconds. | Actuator blocked. | 1. Check that the motor rotor works freely. 2. Replace the vacuum motor if necessary. |

General alarms

| <i>Alarm code</i> ----- <i>Description</i> | <i>Meaning</i> | <i>Condition</i> | <i>Effect</i> | <i>Service Suggestions</i> |
|---|--|--|-------------------------------|--|
| E24 ----- VALVE. OPEN CIRCUIT | Open circuit on Solenoid valve | open circuit | Solenoid valve blocked | Check that there are no open circuits in the Solenoid valve wiring. |
| E25 ----- VALVE. SHORT CIRCUIT | Short circuit on Solenoid valve | short circuit | Solenoid valve blocked | 1. Check that there are no short circuits in the vacuum wiring. 2. If alarm still exists, replace the controller EB1. |
| E26 ----- PEADAL CNT. ERROR | Wiring connection error of pedal | Incorrect wiring connection of the pedal | Drive system blocked | Check the wiring connection of RV1 and RV2 in the pedal box. |
| E27 ----- REALEASE THE PEDAL | Paddle not in rest position when board is turned on. | Voltage on P4-8 of main controller EB1 out of range 2.94V-3.2V with respect to -BAT. | Drive system blocked | 1. Release the pedal. 2. Check that the paddle moves correctly, lubricating if necessary; check the linkage and potentiometer. |
| E28 ----- BRUSH or VACUUM UNDERVOLT AGE | Undervoltage on brush or vacuum motor | Undervoltage | Brush or vacuum motor blocked | 1. Check the battery voltage under no-load conditions and under load. Replace the faulty battery/batteries if necessary. 2. Recharge the batteries by performing a complete charging cycle. |
| E29 ----- CAN DISCONNECTI ON | CAN communication failure | CAN communication between main controller EB1 and UI controller EB2 failed | Function blocked | Check the connection of the communication cable on H3.1 and H3.3 |
| E30 ----- TRATION UNDERVOLTA GE | Undervoltage on traction motor | The battery voltage remains below certain value (18.4V for WET CELL batteries, 19.6V for GEL Batteries, 22.4V for Nexsys TPPL batteries, < 21 V for li-ion battery). | Drive system blocked | 1. Check the battery voltage under no-load conditions and under load. Replace the faulty battery/batteries if necessary. 2. Recharge the batteries by performing a complete charging cycle. |
| E31 ----- BRUSH UNDERVOLTA GE | Undervoltage on brush motor | The battery voltage remains below certain value (20.4V for WET CELL batteries, 21.6V for GEL batteries, 22.8V for Nexsys TPPL batteries, 22 V – 21.5 V for li-ion battery). | Brush system blocked | 1. Check the battery voltage under no-load conditions and under load. Replace the faulty battery/batteries if necessary. 2. Recharge the batteries by performing a complete charging cycle. |

| General alarms | | | | |
|--|--|---|---|---|
| <i>Alarm code</i> ----- <i>Description</i> | <i>Meaning</i> | <i>Condition</i> | <i>Effect</i> | <i>Service Suggestions</i> |
| E33 ----- VACUUM UNDERVOLTAGE | Undervoltage on vacuum motor | The battery voltage remains below certain value (19.4V for WET CELL batteries, 20.6V for GEL batteries, 22.6V for Nexsys TPPL batteries, 21.5 V – 21 V for li-ion battery). | Vacuum system blocked | <ol style="list-style-type: none"> 1. Check the battery voltage under no-load conditions and under load. Replace the faulty battery/batteries if necessary. 2. Recharge the batteries by performing a complete charging cycle. |
| E34 ----- ACT. LIMIT ERROR | Incorrect status of actuator limit switch | Incorrect status of actuator limit switch detected | Abnormal actuator movement | <ol style="list-style-type: none"> 1. Check the wiring connection of the actuator limit switch m0, m1, m2. 2. If the error still exists, replace the actuator. |
| E35 ----- BATTERY SETUP ERROR | Incorrect battery type configuration | The wiring connections are corresponding to the parameter of battery type "BAT" | Function blocked | <ol style="list-style-type: none"> 1. Check the parameter of battery type "BAT" set in the panel. 2. Check the wiring connection on H2 and H5. 3. If the above methods do not work, check the baud rate of each module and reset to 250kbps if required. For the baud rate setting, refer to "Lithium Ion Battery Module Service Manual (56043180)". |
| E36 ----- SOLUTION OPEN CIRCUIT | Open circuit on solution pump | Open circuit | Solution pump blocked | Check that there are no open circuits in the solution pump wiring. |
| E37 ----- DETERGENT OPEN CIRCUIT | Open circuit on detergent pump | Open circuit | Detergent pump blocked | Check that there are no open circuits in the detergent pump wiring. |
| E38 ----- SOLUTION OR DETE. PUMP SHORT CIRCUIT | Shor circuit on solution or detergent pump | Short circuit | Solution pump or detergent pump blocked | <ol style="list-style-type: none"> 1. Check that there are no short circuits in the detergent pump or solution pump wiring. 2. If alarm still exists, replace the controller EB1. |

Battery and Charger Alarm Codes**Lead Acid Battery Charger Alarm Codes**

| On-board Lead Acid Battery Charger Alarms | | | | |
|---|---|--|-----------------------|---|
| <i>Alarm code</i> ----- <i>Description</i> | <i>Meaning</i> | <i>Condition</i> | <i>Effect</i> | <i>Service Suggestions</i> |
| C1 ----- --- CHARGER CONN. | Connection between charger and battery failed | Before charging, no connection to battery or reversal connection to battery | Battery charger block | Disconnect the AC, turn off the machine and check the accessible battery cable connections. |
| C2 ----- --- BATTERY OV UV | Battery overvoltage or undervoltage | Before charging Battery voltage over 31V or Battery voltage under 10V. During charging, Battery voltage under 9V. | Battery charger block | 1. Check the connections of the batteries and the voltage of the installed batteries. 2. Disconnect and reconnect the battery charger. |
| C3 ----- --- CHARGER OVERTEMP | Battery charger internal temperature over high | Battery charger internal temperature over high | Battery charger block | Stop charging and wait for the charger to cool down to room temperature. |
| C4 ----- --- TIME I EXPIRED | Charging phase I expired | Battery excessively discharged or at end-of-life cycle | Battery charger block | If the problem persists, replace the batteries. |
| C5 ----- --- TIME II EXPIRED | Charging phase II expired | Battery excessively discharged or at end-of-life cycle | Battery charger block | If the problem persists, replace the batteries. |
| C6 ----- - CHARGER FAULT | Battery charger overcurrent | Battery charger current over 30A | Battery charger block | Replace the battery charger. |
| C7 ----- - CHARGER COMM. | Communication error between the charger and the battery | Signal from battery charger via gate H5.2 is out of scope | Battery charger block | Disconnect the AC, turn off the machine and check the communication cable connection. |

Li-ion Battery Error Codes

| Li-ion Battery Error Codes | | | | |
|--|---|--|--|--|
| Alarm code ----- Description | condition | Effect | | Service Suggestions |
| | | Machine action during use | Machine action during charging | |
| L3 ----- RECUPERATION ALARM | Too much regenerative charge during dynamic braking on a slope with fully charged batteries. | Error message flashing, traction disabled, other functions (brush, vacuum) can work. | ----- | Use the machine only on the allowed slope and don't push it manually. If possible, turn on the brush and vacuum to consume some charge. The error is latching, machine reset required after the conditions normalized. |
| L4 ----- CAN ERROR | CAN wiring/contact error or bad Node-ID configuration or bad Baud rate configuration. | Error message flashing, machine completely disabled. | Error message flashing. If the CAN connection between the battery and charger is functioning, the charging can continue. | Turn off the machine, check the accessible wires/connections. Check the baud rate of each module and reset to 250kbps if required. For the Node-ID and baud rate setting, refer to "Lithium Ion Battery Module Service Manual (56043180)". Machine reset required after the conditions normalized. |
| L5 ----- OVERCHARGE ERROR | Overcharge detected or too much regenerative charge during dynamic braking on a slope with fully charged batteries. | Error message flashing, machine completely disabled. | Charging stopped. | Use the machine only on the allowed slope and don't push it manually. If possible, turn on the brush and vacuum to consume some charge. The error is latching, machine reset required after the conditions normalized. |
| L6 ----- SHORT CIRCUIT ERROR | Short circuit detected | Error message flashing, machine completely disabled. | Charging stopped. | Turn off the machine, check the accessible wires/connections. Restart the machine, if error still exists, replace the battery. |
| Alarm L7 ----- FET ERROR | Internal failed FET detected | Error message flashing, machine completely disabled | Charging stopped. | Please do a "machine reset", if error still exists, replace the battery. |

| Li-ion Battery Error Codes | | | | |
|---|--|---|---|---|
| <i>Alarm code</i> ----- <i>Description</i> | <i>condition</i> | <i>Effect</i> | | <i>Service Suggestions</i> |
| | | <i>Machine action during use</i> | <i>Machine action during charging</i> | |
| L8 ----- OVERCURRENT ERROR | Overcurrent detected. | Error message flashes, machine disabled. In the overcurrent condition, the battery will disable its output after 5 seconds and the machine will switch off. | Charging stopped. | Turn off the machine, check the accessible wires/connections. Reduce the load, check the free rotation of the wheels and brush. |
| L9 ----- UNDERCHARGE ERROR | Battery is undercharge d. | Error message flashes, machine disabled. In the undercharge condition, the battery will disable its output after 5 seconds and the machine will switch off. | ----- | Turn off the machine and recharge the batteries. |
| L10 ----- BATTERY TEMP ERROR | Over- or under temperature warning during charging or discharging. | Error message flashes, the machine switch off after 5 seconds. | The charging will be stopped and will be automatically resumed when the temperature is within specified limits. | When the machine is in use, try to reduce the load. Pay attention to the normal operation temperatures. Check the cooling fan inlet of the battery and clean if it necessary. |
| L11 ----- MODULE DEFECT ERROR | One or more modules defected. | Error message flashes, no other action on machine side. If the battery module has a serious error, the output of the whole battery pack can be disabled, in this case the machine is off. | The charging of the operational modules can continue. | Please do a "Machine reset". If the error exists, replace the defected modules. The LED on the defective module is red while it is green on the normal module. Also, the voltage output of the defective module is zero. Note: If the machine is equipped with more than 1 module and they are fully operational, the machine can be used, but the error message is always on the LCD. |

**Note:**

If any other error messages appear on the display of the machine, please try to perform a “machine reset” or a “battery reset”. If the error still exists, call the Nilfisk service.

Machines with 1 module:

In some battery-related error conditions, the output of the module is disabled, and the machine will switch off, error messages will not appear on the display. Please check the LEDs on the battery modules.

RED: battery output disabled.

Machines with more than 1 module installed:

If the conditions allow, only the defected module(s) will switch off. The other modules can supply the voltage for the machine, and it can continue to operate or show the error messages.

Li-ion battery charger error codes

| Li-ion battery charger error codes | | | |
|---|--|------------------------|--|
| <i>Alarm code</i> | <i>condition</i> | <i>Effect</i> | <i>Service Suggestions</i> |
| <i>Description</i> | | | |
| D1 CHARGER INT. ERROR | Internal charger fault. | Battery charger block. | Disconnect the AC for minimum 30 seconds. If the problem persists, replace the battery charger. |
| D2 BATTERY OVERVOLTAGE | Battery voltage is too high. | Battery charger block. | Check the battery status LED, disconnect the AC, and check the accessible battery cable connections. |
| D3 CHARGE TIMEOUT | Charge time limit exceeded. | Battery charger block. | Check the battery status LED, disconnect the AC, turn off the battery, and check the accessible battery cable connections. |
| D4 BATTERY CONN. ERROR | Insufficient battery DC connection. | Battery charger block. | Disconnect the AC and check the accessible battery cable connection. |
| Alarm D5 AC OVERVOLTAGE | The AC voltage is too high. | Battery charger block. | Disconnect the AC and check the AC connections and the power grid. Please be aware that the charger works in 85-270V AC range. |
| D6 AC UNDERVOLTAGE“ | The AC voltage is too low. | Battery charger block. | Disconnect the AC and check the AC connections and the power grid. Please be aware that the charger works in 85-270V AC range. |
| D7 CHARGER COMM. ERROR | Communication error between the charger and the battery. | Battery charger block. | Disconnect the AC and check the accessible communication cable connections. |

**Note:**

The charger error doesn't cause any machine action, the machine can only display the error codes of the charger. The battery and charger error codes in this manual cover more specified errors.

Display setting

Black box: Recording of Alarms, Parameters, Partial Operating Time Counter

The alarms activated during normal machine operation are stored and can be read in the corresponding log (Alarm Log Screen).

SUPERVISOR SETTING

The supervisor allows to check some additional information on some machine operating parameters and to adjust some settings according to specific requirements.

Display, Main Screen (D, Figure 1)

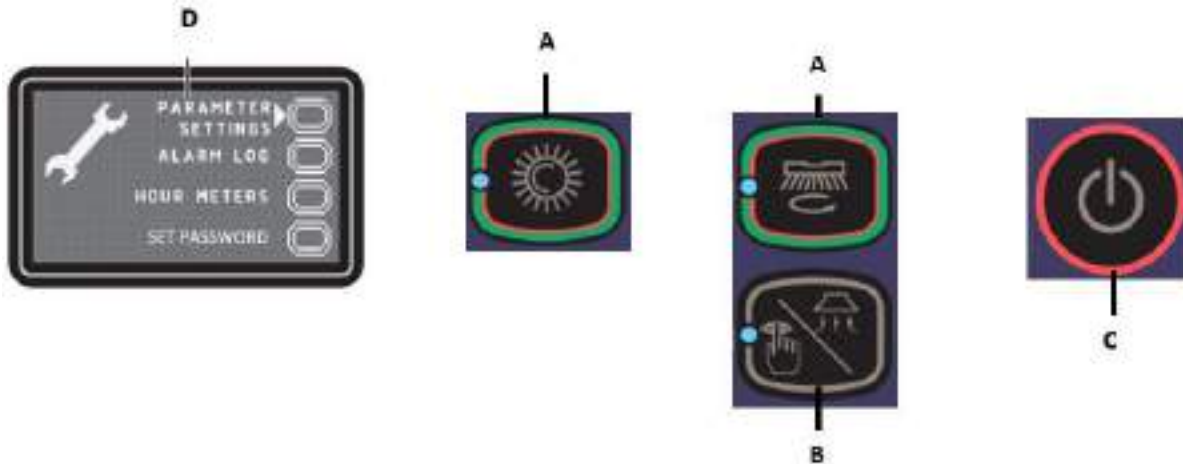

Figure 1

- Access supervisor password page.
 - Press and hold the push-button (A) and (B) simultaneously.
 - Press and release the switch (C).
 - Release the push-button (A) and (B) after the logo disappears on the screen.
- Enter the supervisor password 4444.
- Press the push-button (B) to change the machine settings (see Machine Settings Screen section).
- Press push-button (A) to move the arrow to "ALARM LOG" and press the push-button (B) to check for any stored machine alarms (see Alarms Log Screen section).
- Press push-button (A) to move the arrow to "HOUR METERS" and press the push-button (B) to check the machine's hours of operation (see Operating Time Counter Screen section).
- Press push-button (A) to move the arrow to "SET PASSWORD" and press the push-button (B) to enter the user password management menu.

Display, Machine Settings Screen

The machine settings screen (Figure 2) functions allow you to customize some parameters described in the following table of modifiable parameters.





- Press the One-Touch button  to select the option you need.
- Press the vacuum button  to confirm the option you select.
- To return to the main screen (D, Figure 1), press the One-Touch button  to select the option "EXIT", then press the vacuum button .



Figure 2

| TABLE OF MODIFIABLE PARAMETERS | | Values | | | |
|--------------------------------|--|--------------|-----------------------|-----------------|--------|
| Code | Description | Minimum | Factory Setting | Maximum | |
| CHM1 | Detergent concentration level 1 | 0.25 % | 0.25 % (1:400) | 3 % (1:33) | |
| CHM2 | Detergent concentration level 2 | 0.25 % | 0.80 % (1:125) | 3 % (1:33) | |
| CHAS | Detergent empty alarm sound | OFF | ON | ON | |
| P1/P3 | Level 1 solution flow rate in relation to level 3 (flow rate as function of speed) | 0 % | 25 % | 100 % | |
| P2/P3 | Level 2 solution flow rate in relation to level 3 (flow rate as function of speed) | 0 % | 50 % | 100 % | |
| P3 | Level 3 solution flow rate (flow rate as function of speed) | SC650 66D | 1 cl/m | 5.1 cl/m | 8 cl/m |
| | | SC650 71D | 1 cl/m | 5.5 cl/m | 8 cl/m |
| | | SC650 85D | 1 cl/m | 6.5 cl/m | 8 cl/m |
| | | SC650 71C | 1 cl/m | 5.5 cl/m | 8 cl/m |
| P4 | Enablement of level 4 (3.8l/min in regardless of speed) | OFF | OFF | ON | |
| SPT | EcoFlex function timer | 0 (disabled) | 60 sec. | 300 sec. | |
| XPRES | Brush deck extra pressure enabling | SC650 66D | OFF | ON | ON |
| | | SC650 71D | OFF | ON | ON |
| | | SC650 85D | OFF | ON | ON |
| | | SC650 71C | OFF | OFF | ON |
| FVMIN | Minimum forward speed | 0 % | 15% | 100 % | |
| FVMAX | Maximum forward speed | 10 % | 100% | 100 % | |
| RVMAX | Maximum reverse speed | 10 % | 50% | 50 % | |
| BAT (**) | Installed battery type (see table) | 0 | 3 | 8 | |
| TOFF | Automatic shut-off time | 0 (disabled) | 240 sec. | 600 sec. | |
| BRGH | Display contrast | 5 | 100 | 100 | |
| VRID | Vacuum power in silent mode | 1 | 5 | 5 | |
| DRPMA | Reduced disc brush rpm activation threshold A | 5 | 10 | 40 | |
| DRPMB | Reduced disc brush rpm activation threshold B | 5 | 20 | 40 | |
| CRPMA | Reduced cylindrical brush rpm activation threshold A | 5 | 15 | 40 | |
| CRPMB | Reduced cylindrical brush rpm activation threshold B | 5 | 25 | 40 | |
| RESET | Restore factory settings for all parameters | OFF | OFF | ON | |

(*) Increase the value of this parameter to reduce the brush motor speed in a wider range of applications and vice versa.

(**) As described in the Use/Operation chapter, set the machine and the on-board battery charger (where fitted) based on the type of battery to be installed by modifying the BAT parameter as shown in the following table:

| SETTING | BATTERY TYPE | CHARGING CURRENT |
|---------|-----------------|--------------------|
| 1 | WET | STANDARD |
| 2 | GEL-AGM | |
| 3 | GEL EXIDE® type | |
| 4 | WET | REDUCED (see note) |
| 5 | GEL-AGM | |
| 6 | GEL EXIDE® type | |
| 7 | NEXSYS | STANDARD |
| 8 | LI-ION | STANDARD |



NOTE:

When using batteries with a capacity lower than 160Ah@5h (in case of doubt, refer to the battery documents), to avoid battery overheating during charging procedure, use the REDUCED charging current with setting 4, 5 or 6 shown in the table, according to the type of batteries installed.

Display, Machine Settings Screen (Continues)

Only when on reaching the last parameter “Reset”, and then pressing the EcoFlex button  together with

the detergent percentage adjustment button  will the following hidden parameters be displayed.

| HIDDEN PARAMETERS | | | | | |
|-------------------|---|------------|-----------------|------------|--|
| Code | Description | Min. Value | Factory Setting | Max. Value | Meaning |
| TSERV | Service advisory timer | 0 | 0 | 1000 | Set to a value X greater than 0 if you wish the “Service Advisory” icon to be displayed every X hours of machine running time (according to the main operating time counter). To reset the hour counter for the icon display countdown (until the next service advisory), press the BURST and vacuum buttons for 10 seconds with the display on the “SERVICE MENU” page. |
| AR | Maximum acceleration ramp (s) | 0.2 | 6.0 | 8.0 | Increase to obtain a less abrupt response when accelerating, and vice versa. |
| DR | Maximum deceleration ramp (s) | 0.2 | 2.0 | 8.0 | Increase to obtain a less abrupt response when decelerating, and vice versa. WARNING: increasing this value increases the braking distance. |
| IR | Maximum deceleration ramp on inversion (s) | 0.5 | 1.0 | 5.0 | This is the maximum current which can be supplied to the disc brush deck. WARNING: increasing this value increases the risk of the motors overheating. |
| VS1 | Disc brush motor protection threshold(A) | 30 | 50 | 55 | This is the maximum current which can be supplied to the disc brush deck. WARNING: increasing this value increases the risk of the motors overheating. |
| VS2 | Cylindrical brush motor protection threshold(A) | 30 | 55 | 60 | This is the maximum current which can be supplied to the cylindrical brush deck. WARNING: increasing this value increases the risk of the motors overheating. |
| VDEAD | Paddle potentiometer dead zone(V) | 0.0 | 0.3 | 1.0 | Increase if the alarm T3 appears in the rest position and it is not possible to adjust the system’s mechanics. (Speed regulation will, however, be more difficult to modulate) |
| INOM | Rated traction current(A) | 10 | 15 | 15 | This is the maximum continuous current which can be supplied to the electric wheel drive unit. WARNING: increasing this value increases the risk of the motor overheating. |
| IMAX | Maximum traction current(A) | 10 | 45 | 45 | This is the maximum instantaneous current which can be supplied to the electric wheel drive unit. WARNING: increasing this value increases the risk of the motor overheating. |
| TMAX | Time intervention protection for IMAX(s) | 0 | 12 | 60 | This is the reaction time of the electric wheel drive unit protection device when overloaded: this parameter is used in conjunction with IMAX to obtain the most appropriate response curve for the overload protection motor actuation system. WARNING: increasing this value increases the risk of the motor overheating. |

| | | | | | |
|------|-------------------------------|---|---|---|---|
| BRT | Brush type | 0 | 0 | 3 | <p>“0” stands for 66disc brush, “1” stands for 71disc brush, “2” stands for 85disc brush and “3” stands for 71cylindrical brush.</p> <p>WARNING: setting this value based on the machine actual configuration, otherwise the extra pressure of the brush will not work correctly</p> |
| PDET | Detergent pump mode selection | 0 | 1 | 1 | <p>“0” stands for no detergent pump, and “1” stands for peristaltic pump.</p> <p>WARNING: setting this value based on the machine actual configuration, otherwise detergent icon on the display will be incorrect and detergent will not work.</p> |

System for Flow Rate Regulation as Function of Speed

Solution flow levels 1, 2 and 3 regulate the flow of detergent solution on the basis of the machine speed so as to keep the quantity of solution dispensed per square meter of floor treated constant.

The reference flow level is level 3: based on the setting of the corresponding parameter P3, the voltage of the water pump (and of the detergent pump when fitted) is regulated so that the quantity of solution in centiliters per meter travelled by the machine is constant and equal to the value set in the parameter.

For example, for P3 = 5.1, the machine will dispense 5.1 centiliters of solution per meter travelled, which equates (for the standard deck width of 650 mm) to 7.7 centiliters per square meter of floor treated.

Levels 1 and 2 are defined via the corresponding parameters P1 and P2 as a % of level 3. For example, for P1 = 25 and P2 = 50, P1 and P2 are respectively $\frac{1}{4}$ (25%) and $\frac{1}{2}$ (50%) of the reference flow rate P3

The default values (the same as in the example above) are summarized in the table, with the corresponding flow rate values in liters per minute, dependent on machine speed, given as a reference.

| SC650 DISC detergent flow (as a function of speed) (standard setting) | | | |
|---|---------|---------|---------|
| | Level 1 | Level 2 | Level 3 |
| Liters/minute @ 2 km/h | 0.4 | 0.8 | 1.7 |
| Liters/minute @ 3 km/h | 0.6 | 1.2 | 2.5 |
| Liters/minute @ 4 km/h | 0.8 | 1.7 | 3.4 |
| Centiliters per meter cleaned (constant) | 1.2 | 2.5 | 5.1 |
| Centiliters per meter ² cleaned | 1.9 | 3.8 | 7.7 |

Level 4 (when enabled) by parameter P4, is independent of any parameter and supplies the maximum possible quantity of solution as it keeps the water pump of the supply system constantly running at 24V. (with the brush rotating)

| SC650 DISC detergent flow rate | |
|--------------------------------|---------|
| | Level 4 |
| Liters/minute | 3.8 |

Display, Alarms Log Screen

The alarms log screen (Figure 3) function allows you to check any alarms stored on the machine. To return to the main screen



(D, Figure 1), press the One-Touch button  to select the option “EXIT”, then press the vacuum button .



Figure 3

Each alarm (See table of alarms in the Main Machine Controller Alarm Codes section) is stored along with the working hour (machine operating time counter) at which it occurred, and all alarms are recorded in the order in which they occurred, from the most recent to the oldest.

The memory holds up to 50 alarm records, after which the oldest are overwritten when new alarms occur. Improper uses of the batteries or battery charger are also recorded, as in the following table:

| On-board Battery Charger Alarms | | | |
|---|---|--|--|
| Alarm code ----- Description | Meaning | Condition | Effect |
| EB-N ----- CONTINUOUS LOW BATTERY VOLTAGE | Time of continuous use with discharged batteries | “N” is the number of hours from key on to off when the battery level is below 20.4V for WET CELL (21.6 for GEL, 22.8 for Nexsys) batteries. This event is not recorded if the usage time is below 10 minutes | Incorrect used by customer. Risk of reduced battery life |
| EC(*) ----- CHARGER DISCONNECTED BEFORE END CYCLE | The battery is suspended before it is fully charged | The charger is unplugged before the battery is fully charged | Incorrect used by customer. Risk of reduced battery life |

(*) Note:

1. No other behavior occurs 30 seconds after the charger is disconnected. The alarm disappears 30 seconds later, and the screen is powered off.
2. Press any button within 30 seconds after the charger is disconnected. The alarm disappears immediately, and the screen is powered off.
3. Restore the charger connection within 30 seconds after the charger is disconnected. The alarm disappears immediately, and the charging state is restored.

Display, Operating Time Counter Screen

The operating time counter screen (Figure 4) function allows you to check the total accumulated hours of work for each machine subsystem:

- (A) TOTAL counter (machine running time)
- (B) DRIVE counter (drive system usage time)
- (C) BRUSH counter (brush rotation system usage time)
- (D) VACUUM counter (vacuum system usage time)

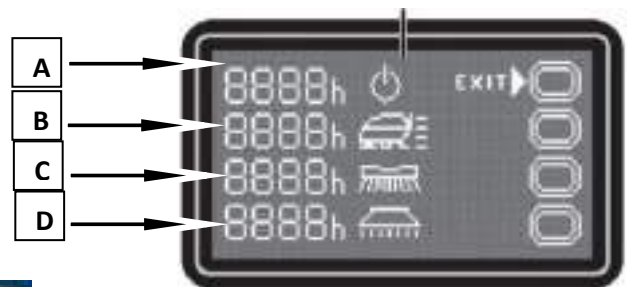



Figure 4

To return to the main screen, press the One-Touch button  to select the option “EXIT”, then press the vacuum button .

Removal and Installation

Main Machine Controller (EB1) Removal/Replacement

- 1 Refer to step 1-6 in "UI Controller (EB2) and Label membrane (EB3) Removal/Replacement."
- 2 After disconnecting the connectors from the UI controller, remove the control panel.
- 3 Disconnect the following connections from Main machine controller sequentially:
 - (A) and (B) Board power supply connection (B+) and (B-)
 - (C) and (D) Traction motor connection (TM+) and (TM-)
 - (E) Brush motor and vacuum motor positive connection (M+)
 - (F) and (G) Brush motor (BM-) and vacuum motor connection (VM-)

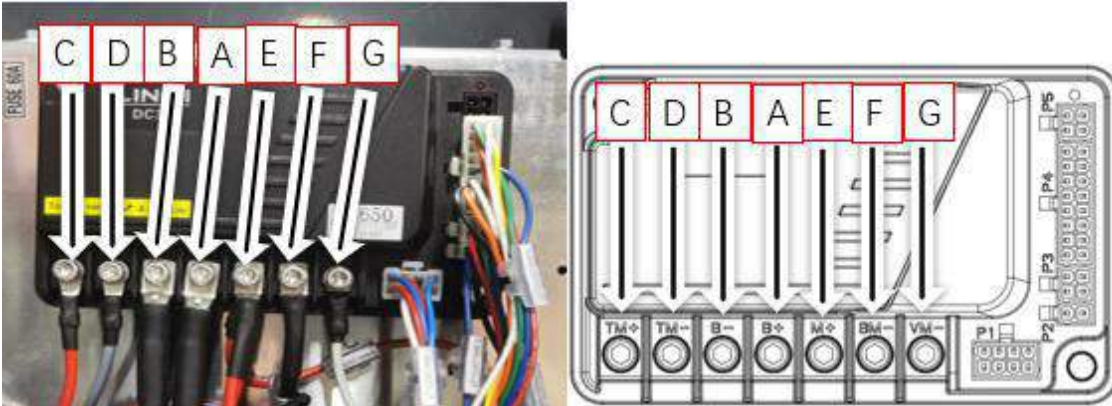

- 4 Disconnect the following connections from Main machine controller sequentially:
 - (H) Water pump and detergent pump and actuator motor power supply connection (P1)
 - (I) Solenoid valve connection (P2)
 - (J) Actuator motor signal and speed potentiometer and maximum speed potentiometer connection (P4)
 - (K) UI controller connection (P3)

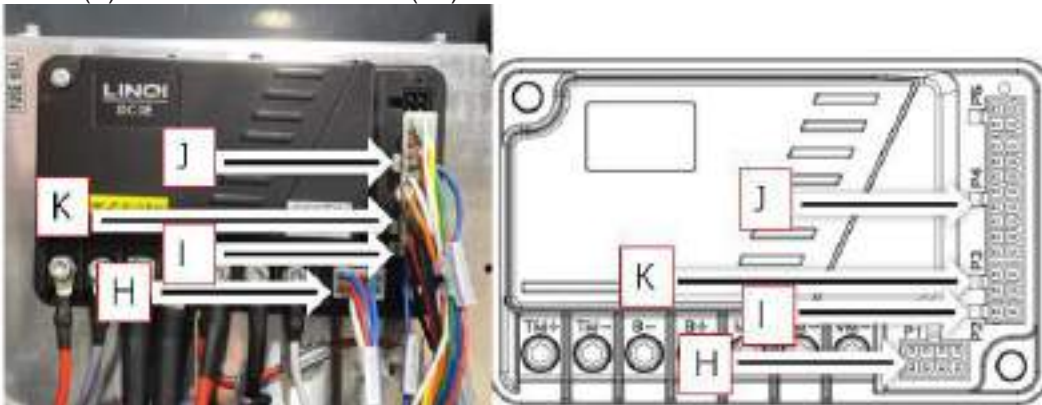

- 5 Unscrew the 2 retaining screws (L) and carefully remove the Main Machine Controller



Assembly

- 6 Assemble the components in the reverse order of disassembly.

UI Controller (EB2) and Label membrane (EB3) Removal/Replacement

UI Controller (EB2)

- 1 Drive the machine on a level floor.
- 2 Turn off the machine.
- 3 Disconnect the battery connector.
- 4 Unscrew the 4 screws (M)
- 5 Unscrew the 2 knobs (N), then lift up the paddle box and fix it with one side tube (shown as O).
- 6 Open the control panel (P), disconnect the following connections sequentially (Figure 15):
 - (Q) and (R) USB and UI controller power supply connection (H6 and H7)
 - (S) and (T) Multicon1 and Li-ion battery connection (H2 and H3)
 - (U) Battery charger connection (H5)
 - (V) Detergent level sensor connection (H4)
 - (W) Main machine controller connection (H1)
- 7 Unscrew the 4 screws (X), then remove the UI Controller (Y)

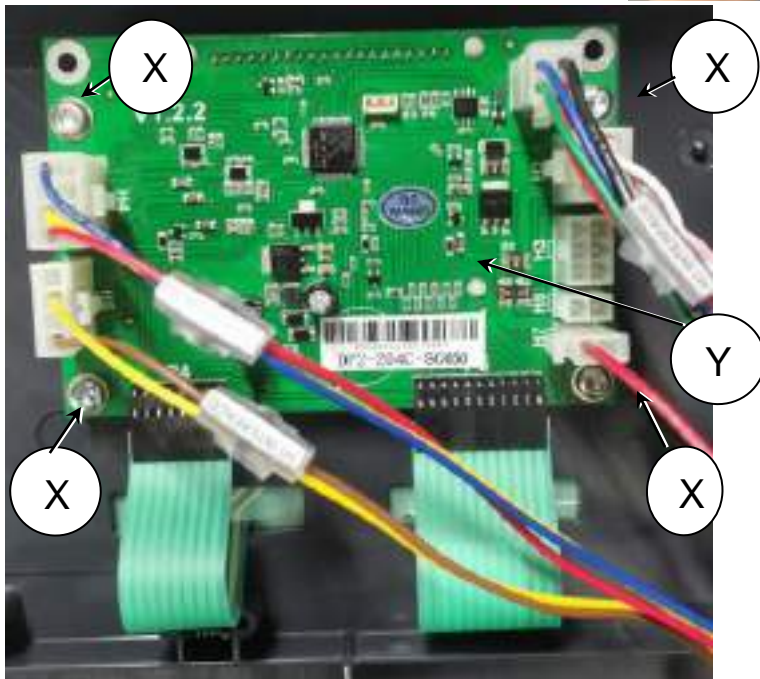
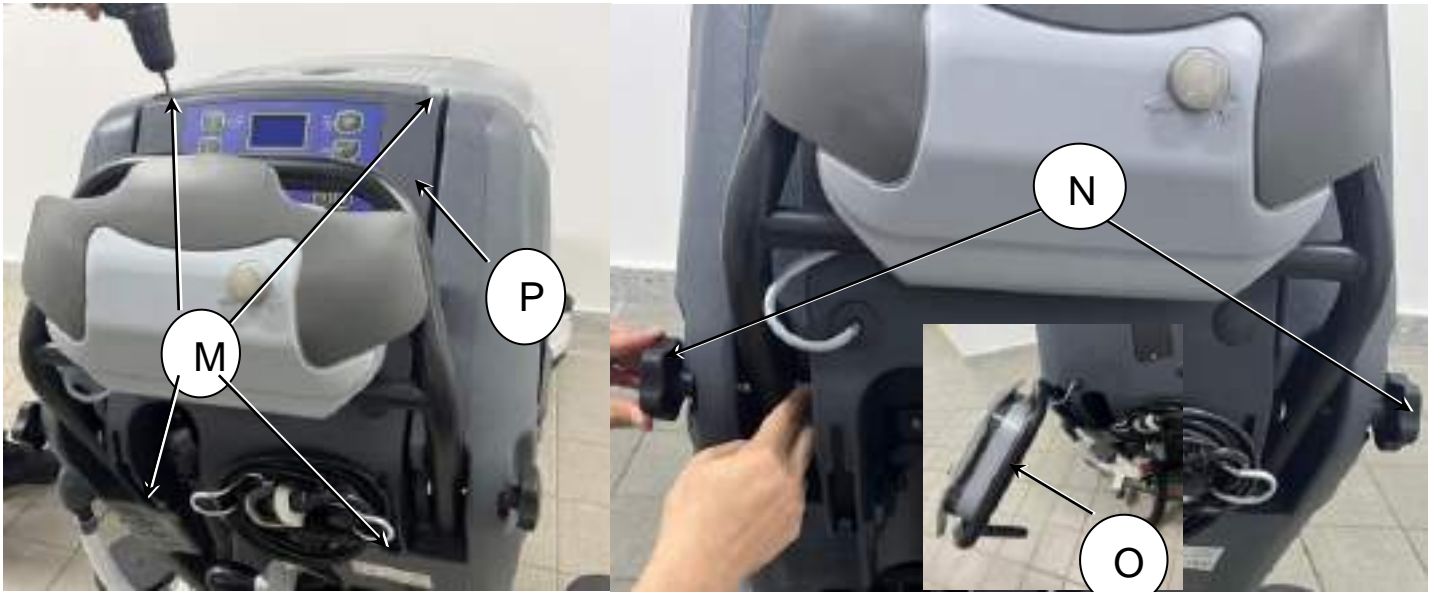

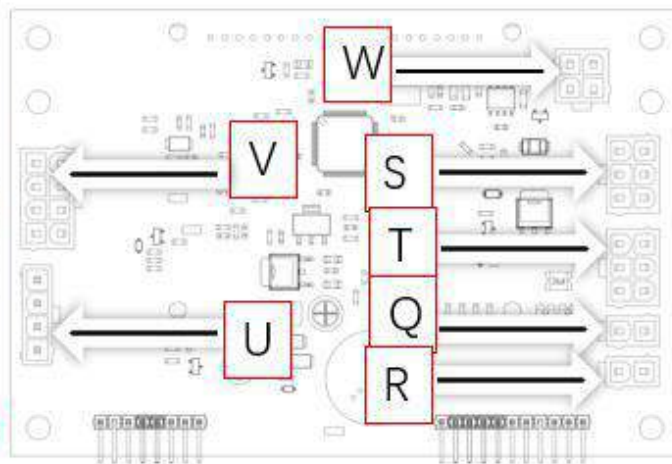
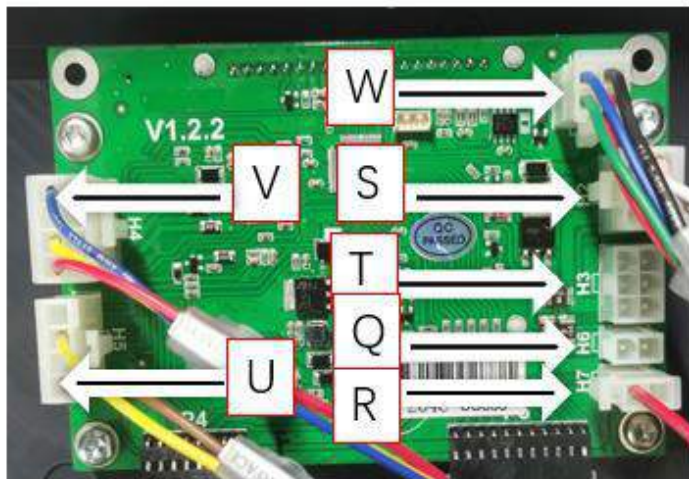

Label membrane (EB3)

- 8 Perform steps 1 to 6 for removal of the UI Controller
- 9 Disconnect the following connections sequentially:
 - (a) Flat connection (P4)
 - (b) Flat connection (P5)
- 10 Carefully raise the Label membrane (Z), detaching it from the control panel (P)

Assembly

- 11 Assemble the components in the reverse order of disassembly and note the following:
 - Before fastening the Label membrane (Z), ensure that the flat connections (a) and (b) are correctly run through the slots in the cover (P), then remove the film on the Label membrane to adhere it on the cover (P).

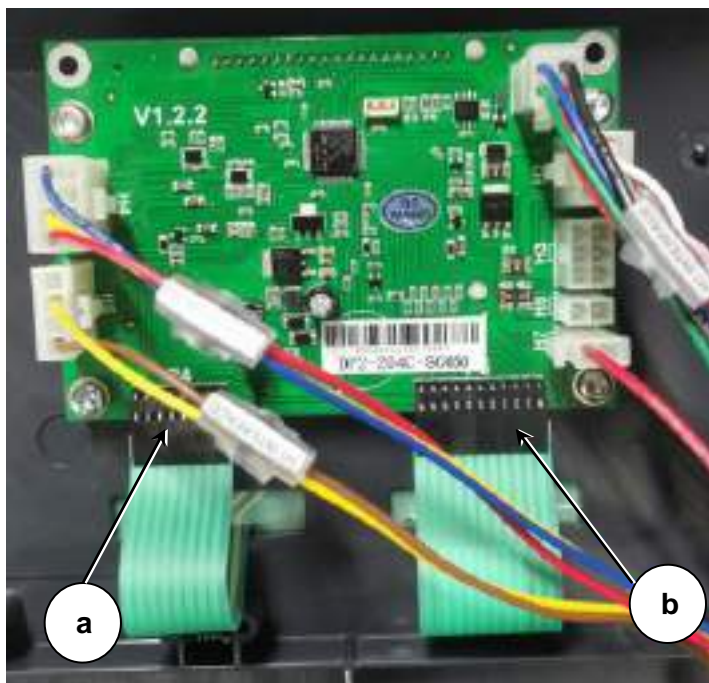

Specifications

Main Machine Controller (EB1) Connectors

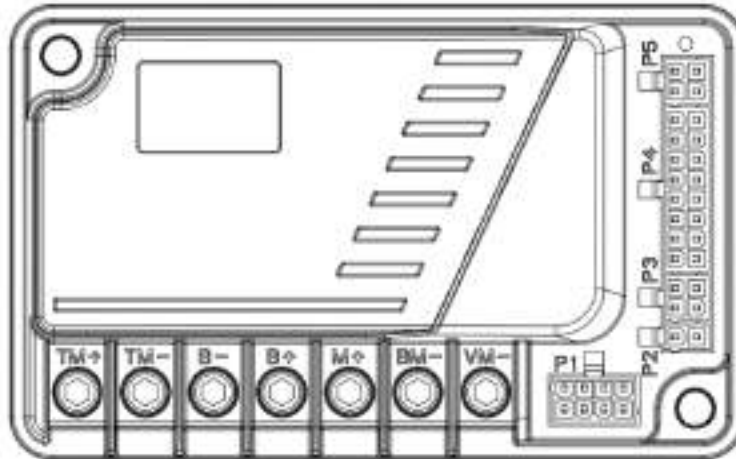

| DC Connections | | | | | |
|----------------|---------------------------------|--------|--------|--------|---------------|
| Pin# | Description | In/Out | V ref. | I max. | Connected to |
| TM+ | Traction Motor + | out | 0-24V | 20A | M3 |
| TM- | Traction Motor - | out | 0-24V | 20A | M3 |
| B- | Battery - | out | 0V | 100A | BAT- |
| B+ | Battery + | out | 24V | 100A | BAT+ |
| M+ | Brush Motor+ and Vacuum Motor + | out | 24V | 90A | M1.1,2 and M2 |
| BM- | Brush Motor - | out | 0V | 60A | M1.1,2 |
| VM- | Vacuum Motor - | out | 0V | 30A | M2 |

| P1: 5557 type, 8-ways | | | | | |
|-----------------------|-------------------------------|--------|--------|--------|--------------|
| Pin# | Description | In/Out | V ref. | I max. | Connected to |
| 1 | N/A | N/A | N/A | N/A | N/A |
| 2 | N/A | N/A | N/A | N/A | N/A |
| 3 | Detergent pump power supply + | out | 0-24V | 3A | M5 |
| 4 | Actuator power supply +/- | out | 0-24V | 7A | M6 |
| 5 | Detergent pump power supply - | out | 0V | 3A | M5 |
| 6 | Water pump power supply - | out | 0V | 10A | M4 |
| 7 | Water pump power supply + | out | 0-24V | 10A | M4 |
| 8 | Actuator power supply +/- | out | 0V | 7A | M6 |

| P2: 5557 type, 2-ways | | | | | |
|-----------------------|-------------|--------|--------|--------|--------------|
| Pin# | Description | In/Out | V ref. | I max. | Connected to |
| 1 | Valve - | out | 0V | 1A | EV1 |
| 2 | Valve + | out | 0-24V | 1A | EV1 |

| P3: 5557 type, 4-ways | | | | | |
|-----------------------|-------------|--------|--------|--------|----------------|
| Pin# | Description | In/Out | V ref. | I max. | Connected to |
| 1 | CAN_L | in/out | 2.5V | <1A | EB2. H1.CAN_L |
| 2 | GND | out | 0V | <1A | EB2. H1.GND |
| 3 | CAN_H | in/out | 2.5V | <1A | EB2. H1.CAN_H |
| 4 | Key_In | In | 24V | <1A | EB2. H1.Key_In |

| P4: 5557 type, 16-ways | | | | | |
|------------------------|---------------------------------|--------|--------|--------|---------------|
| Pin# | Description | In/Out | V ref. | I max. | Connected to |
| 1 | Actuator position 0 microswitch | in | 0V | <1A | M6.m0 |
| 2 | Actuator position 1 microswitch | in | 0V | <1A | M6.m1 |
| 3 | Actuator position 2 microswitch | in | 0V | <1A | M6.m2 |
| 4 | N/A | N/A | N/A | N/A | N/A |
| 5 | N/A | N/A | N/A | N/A | N/A |
| 6 | N/A | N/A | N/A | N/A | N/A |
| 7 | RV2_Low | out | 0V | <1A | RV2.3 |
| 8 | RV2_Signal | in | 0-5V | <1A | RV2.2 |
| 9 | RV1_Signal | in | 14-24V | <1A | RV1.2 |
| 10 | RV1_Low | out | 14-17V | <1A | RV1.3 |
| 11 | N/A | N/A | N/A | N/A | N/A |
| 12 | N/A | N/A | N/A | N/A | N/A |
| 13 | RV1_High | out | 24V | <1A | RV1.1 |
| 14 | N/A | N/A | N/A | N/A | N/A |
| 15 | GND | out | 0V | <1A | M6.m0, m1, m2 |
| 16 | RV2_High | out | 5V | <1A | RV2.1 |

| P5: 5557 type, 4-ways | | | | | |
|-----------------------|-------------|--------|--------|--------|--------------|
| Pin# | Description | In/Out | V ref. | I max. | Connected to |
| 1 | USART_RXD | in | 0-5V | <1A | NA |
| 2 | GND | in | 0V | <1A | NA |
| 3 | USART_TXD | out | 0-5V | <1A | NA |
| 4 | Key_In | in | 24V | <1A | NA |

UI Controller (EB2) Connectors

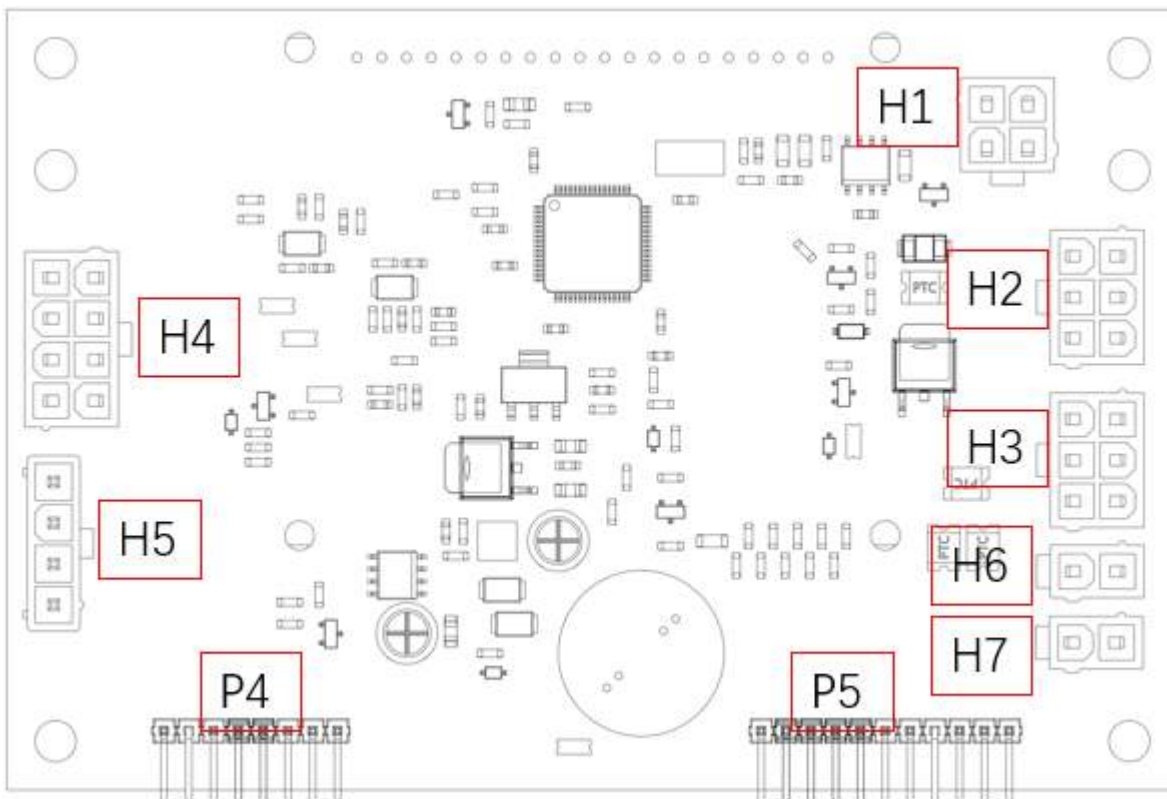

H1: 5557 type, 4-ways

| Pin# | Description | In/Out | V ref. | I max. | Connected to |
|------|-------------|--------|--------|--------|----------------|
| 1 | CAN_L | in/out | 2.5V | <1A | EB1. P3.CAN_L |
| 2 | GND | out | 0V | <1A | EB1. P3.GND |
| 3 | CAN_H | in/out | 2.5V | <1A | EB1. P3.CAN_H |
| 4 | Key_In | In | 24V | <1A | EB1. P3.Key_In |

(*)H2: 5557 type, 6-ways

| Pin# | Description | In/Out | V ref. | I max. | Connected to |
|------|---------------------------|--------|--------|--------|-----------------|
| 1 | CAN_L for Li-ion battery | in/out | 2.5V | <1A | LI-BAT.CAN_L |
| 2 | GND | out | 0V | <1A | LI-BAT.GND |
| 3 | ON/OFF for li-ion battery | in/out | 0-5V | <1A | LI-BAT. BAT WKP |
| 4 | CAN_H for Li-ion battery | in/out | 2.5V | <1A | LI-BAT.CAN_H |
| 5 | N/A | N/A | N/A | N/A | N/A |
| 6 | N/A | N/A | N/A | N/A | N/A |

(*)H3: 5557 type, 6-ways

| Pin# | Description | In/Out | V ref. | I max. | Connected to |
|------|----------------------------|--------|--------|--------|-----------------------|
| 1 | CAN_L for Multicon1 | in/out | 2.5V | <1A | Multicon1.CAN_L |
| 2 | DGND | out | 0V | <1A | Multicon1.GND |
| 3 | ON/OFF for Multicon1 | in/out | 0-5V | <1A | Multicon1. BAT WKP |
| 4 | CAN_H for Multicon1 | in/out | 2.5V | <1A | Multicon1.CAN_H |
| 5 | Power supply for Multicon1 | out | 24V | <1A | Multicon1. Key switch |
| 6 | BAT+ | out | 24V | <1A | Multicon1. BAT+ |

(*) The H2 and H3 interface are symmetrical in design and their connectors can be interchangeable.

| H4: 5557 type, 8-ways | | | | | |
|-----------------------|---|--------|--------|--------|--------------|
| Pin# | Description | In/Out | V ref. | I max. | Connected to |
| 1 | +5V power supply for detergent level sensor | out | 5V | <1A | DS.2 |
| 2 | Detergent level sensor signal | in | 0-5V | <1A | DS.1 |
| 3 | N/A | N/A | N/A | N/A | N/A |
| 4 | GND | out | 0V | <1A | DS.3 |
| 5 | N/A | N/A | N/A | N/A | N/A |
| 6 | N/A | N/A | N/A | N/A | N/A |
| 7 | N/A | N/A | N/A | N/A | N/A |
| 8 | N/A | N/A | N/A | N/A | N/A |

| H5: 5557 type, 4-ways | | | | | |
|-----------------------|---|--------|--------|--------|--------------|
| Pin# | Description | In/Out | V ref. | I max. | Connected to |
| 1 | BAT+ for Li-ion battery charger | out | 24V | <1A | CHARGER BAT+ |
| 2 | Lead-acid charge signal | out | 0V/24V | <1A | LA-CH NC |
| 3 | Li-ion charge signal | out | 0V/24V | <1A | LI-CH NC |
| 4 | Lead-acid battery charger communication | in | 24V | <1A | NA |

| (**)H6: 5557 type, 2-ways | | | | | |
|---------------------------|-------------|--------|--------|--------|--------------|
| Pin# | Description | In/Out | V ref. | I max. | Connected to |
| 1 | GND | out | 0V | 0-2A | USB.GND |
| 2 | BAT+ | out | 24V | 0-2A | USB.BAT+ |

| (**)H7: 5557 type, 2-ways | | | | | |
|---------------------------|-------------|--------|--------|--------|--------------|
| Pin# | Description | In/Out | V ref. | I max. | Connected to |
| 1 | GND | out | 0V | 0-2A | GND |
| 2 | BAT+ | out | 24V | 0-2A | BAT+ |

(**) The H6 and H7 interface are symmetrical in design and their connectors can be interchangeable.

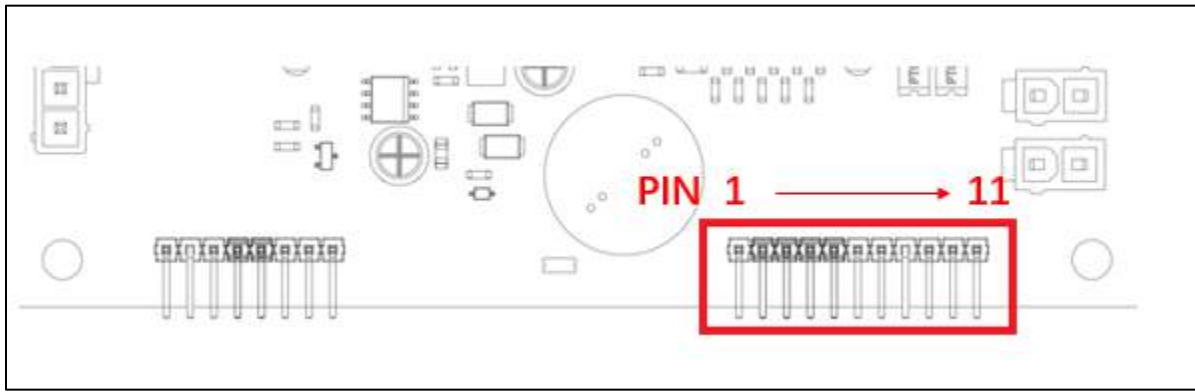

| P4: (2.54 pitch) 11 ways | | | | | |
|--------------------------|---|--------|--------|--------|--------------|
| Pin# | Description | In/Out | V ref. | I max. | Connected to |
| 1 | Power supply – common(GND1) | in/out | 0V | <1A | EB3 |
| 2 | Digit 1 button S1 | out | 0V | <1A | EB3 |
| 3 | Digit 2 button S2 | out | 0V | <1A | EB3 |
| 4 | Digit 3 button S3 | out | 0V | <1A | EB3 |
| 5 | Digit 4 button S4 | out | 0V | <1A | EB3 |
| 6 | Vacuum system switch(S5) | out | 0V | <1A | EB3 |
| 7 | Brush-holder deck lifting/lowering switch(S6) | out | 0V | <1A | EB3 |
| 8 | EcoFlex™system switch(S7) | out | 0V | <1A | EB3 |
| 9 | Washing detergent flow control switch(S8) | out | 0V | <1A | EB3 |
| 10 | Solution flow control switch(S9) | out | 0V | <1A | EB3 |
| 11 | Brush/pad-holder release switch(S10) | out | 0V | <1A | EB3 |

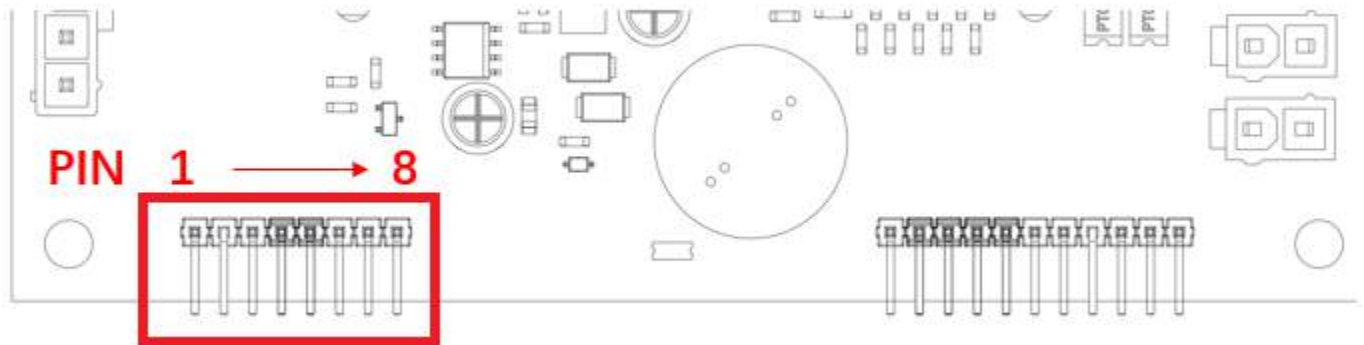

| P5: (2.54 pitch) 8 ways | | | | | |
|-------------------------|--|--------|--------|--------|--------------|
| Pin# | Description | In/Out | V ref. | I max. | Connected to |
| 1 | Vcc for LEDs | out | 5V | <1A | EB3 |
| 2 | LED1 Green EcoFlex™system switch led indicator | out | 5V | <1A | EB3 |
| 3 | LED2 Green Brush/pad-holder release switch warning light | out | 5V | <1A | EB3 |
| 4 | LED3 Green Deck lifting/lowering switch led | out | 5V | <1A | EB3 |
| 5 | LED3 Red Deck lifting/lowering switch led | out | 5V | <1A | EB3 |
| 6 | LED4 Green Vacuum system switch warning light | out | 5V | <1A | EB3 |
| 7 | SW11 ON/OFF switch | out | 5V | <1A | EB3 |
| 8 | GND | out | 0V | <1A | EB3 |

Shop Measurements

The following tables contain some “real world” shop voltage measurements to help you recognize what “normal” looks like. All voltage values were measured with the black (Negative) voltmeter lead connected to the main battery negative unless otherwise specified.

Shop Measurements - Main Machine Controller (EB1)

Battery volts at battery, power on = 25.68V

Power Supply

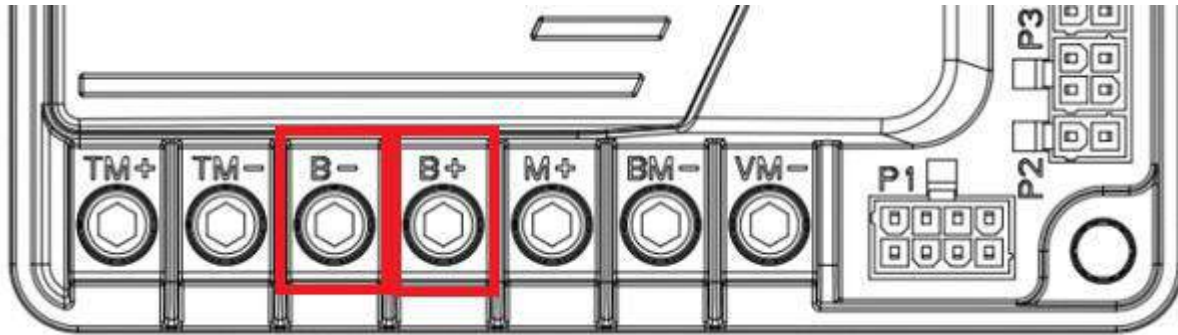

| PIN | Color | Description | Measured | Comments |
|-----|-------|---------------------------------|----------|-----------|
| B+ | Red | Electronic board power supply + | 24.7v | Vacuum on |
| B- | Black | Electronic board power supply - | 0.049V | Vacuum on |

Brush Motor

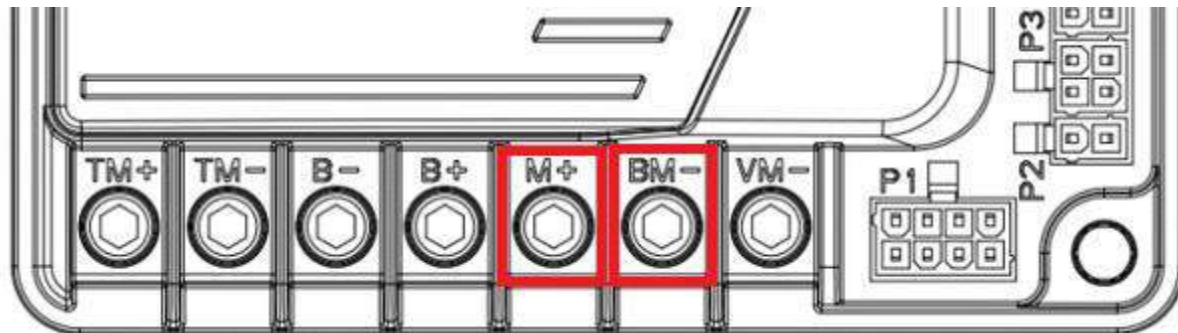

| PIN | Color | Description | Measured | Comments |
|-----|-------|---------------|--|----------------------------|
| M+ | Red | Brush motor + | 25.55V (off), 25.31V (on) | Constant Positive |
| BM- | Black | Brush motor - | 25.55V (off), 0.13v (on without RPM control activated) 5.4v (on with RPM Control Active – set at 20) | PWM Battery Negative |

Drive Motor

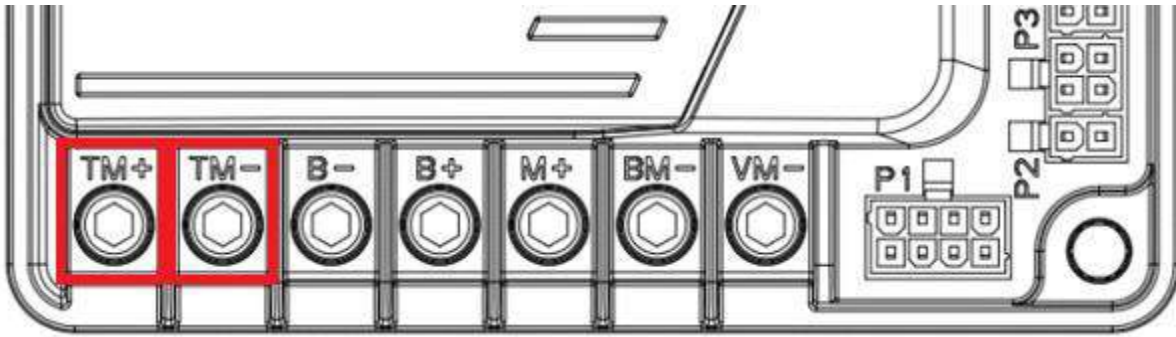

| PIN | Color | Circuit Description | Measured | | | | |
|------------|-------|---------------------|----------|---------------|-------------------|---------|---------|
| | | | Neutral | Fwd - Initial | Reverse - Initial | FWD Max | REV Max |
| TM+ | Red | Drive motor + | 0.001v | 1.2v | 0.001v | 25.4v | 0.001v |
| TM- | Gray | Drive motor - | 0.001v | 0.002v | 1.5v | 0.001v | 15.59v |
| TM+ to TM- | | | 0.001v | 1.2v | -1.6v | 25.4v | -13.6v |

Vacuum Motor

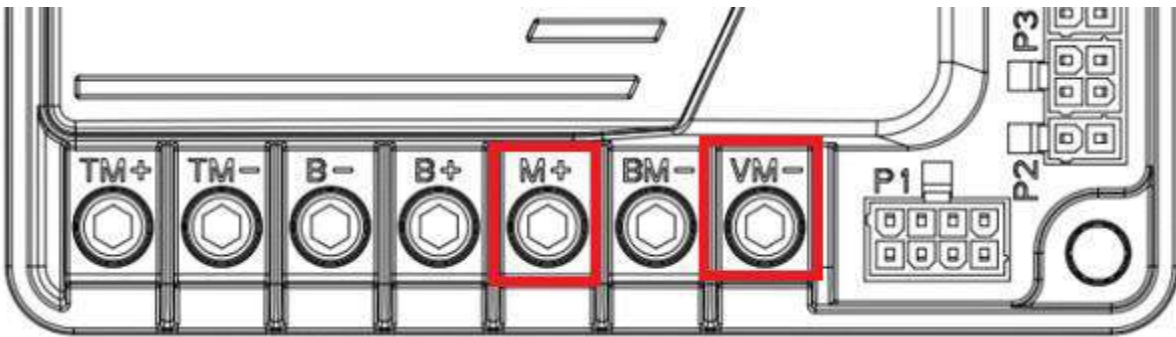

| PIN | Color | Description | Measured | Comments |
|-----|-------|------------------------------|---|-------------------|
| M+ | Red | Vacuum system power supply + | 25.59v (off) 24.51v (on) | Constant Positive |
| VM- | White | Vacuum system power supply - | 25.58v (off) 1.06v (on high) 5.29v (on Quiet mode VRID parameter = 5) | |

P1

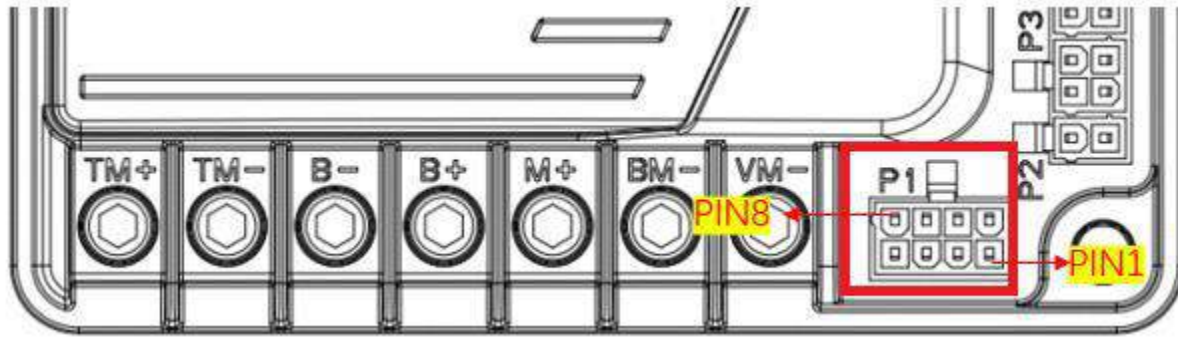

| PIN | Color | Circuit Description | Measured | Comments |
|-----|-------|--------------------------------|--|-------------------|
| 1 | N/A | N/A | N/A | N/A |
| 2 | N/A | N/A | N/A | N/A |
| 3 | White | Detergent pump power supply + | 8.01v(min flow rate) 24v(max flow rate) | PWM Positive |
| 4 | Red | Deck actuator power supply +/- | 0.42v(Stationary) 1.3v (going up) 25.1v (going down) | |
| 5 | Blue | Detergent pump power supply - | 0.001v v(max flow/min flow rate) | Constant Negative |
| 6 | Black | Water pump power supply - | 0.002v(max flow/min flow rate) | Constant Negative |
| 7 | Red | Water pump power supply + | 4.04v(min flow rate) 24v(max flow rate) | PWM Positive |
| 8 | Blue | Deck actuator power supply -/+ | 0.42v(Stationary) 25.3v (going up) 1.3v (going down) | |

P2

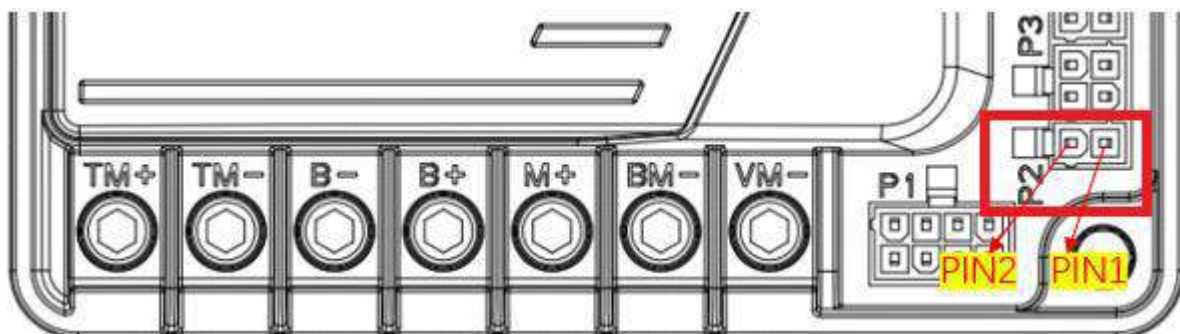

| PIN | Color | Circuit Description | Measured | Comments |
|-----|-------|-------------------------------|------------------------------|-------------------|
| 1 | Brown | Solenoid valve power supply - | 0.001v (on) 0.001v (off) | Constant Negative |
| 2 | Blue | Solenoid valve power supply + | 24.01v (max) 0.001v (min) | PWM Positive |

P3

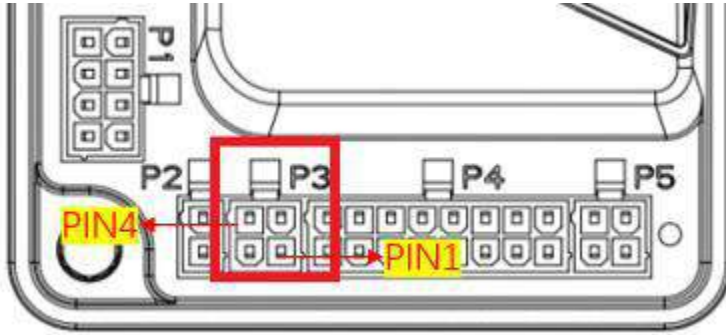

| PIN | Color | Circuit Description | Measured | Comments |
|-----|-------|---------------------|-----------------------------|------------------------|
| 1 | Blue | CAN_L | 2.38v (on) 0 v (off) | |
| 2 | Black | GND | 0v (on/off) | |
| 3 | Green | CAN_H | 2.57v (on) 0v (off) | |
| 4 | Red | Key_In | 25.23v (on) 0.001v (off) | with lead acid battery |

P4

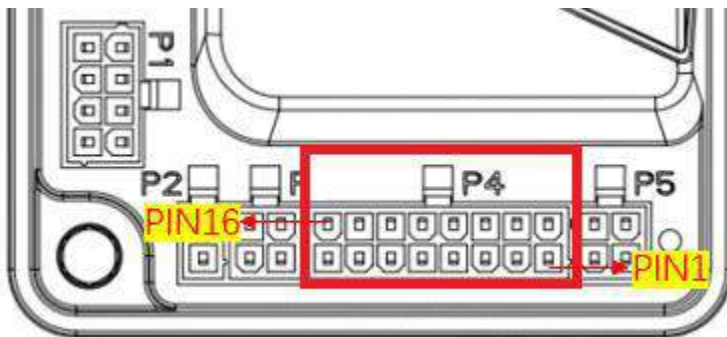

| PIN | Color | Circuit Description | Measured | Comments |
|-----|--------|-------------------------------|---|----------|
| 1 | White | ACTUATOR POS.0 MICROSWITCH | 13.1v(retracted) 0v(work) 0v(extra pressure) | |
| 2 | Yellow | ACTUATOR POS.1 MICROSWITCH | 0v(retracted) 12.97v(work) 0v(extra pressure) | |
| 3 | Orange | ACTUATOR POS.2 MICROSWITCH | 0v(retracted) 0v(work) 13.1v(extra pressure) | |
| 4 | N/A | N/A | N/A | N/A |
| 5 | N/A | N/A | N/A | N/A |
| 6 | N/A | N/A | N/A | N/A |

| | | | | |
|----|--------|--------------------|---|-----|
| 7 | Purple | RV2 power supply - | 0v(neutral/Fwd-initial/Reverse-initial/FWD Max/ REV Max) | |
| 8 | White | RV2 signal | 0.508v(FWD Max) 2.6v(Fwd-initial) 2.94v(neutral) 3.2v(Reverse-initial) 5.47v(REV Max) | |
| 9 | Green | RV1 signal | 14.88v(Minimum speed) 25.22v(Maximum speed) | |
| 10 | Red | RV1 power supply - | 14.88v(Minimum speed) 16.24v(Maximum speed) | |
| 11 | N/A | N/A | N/A | N/A |
| 12 | N/A | N/A | N/A | N/A |
| 13 | Blue | RV1 power supply + | 25.23v(Minimum speed / Maximum speed) | |
| 14 | N/A | N/A | N/A | N/A |
| 15 | Black | ACTUATOR GND | 0v(retracted) 0v(work) 0v(extra pressure) | |
| 16 | Yellow | RV2 power supply + | 5.51v(neutral/Fwd-initial/Reverse-initial/FWD Max/ REV Max) | |

P5

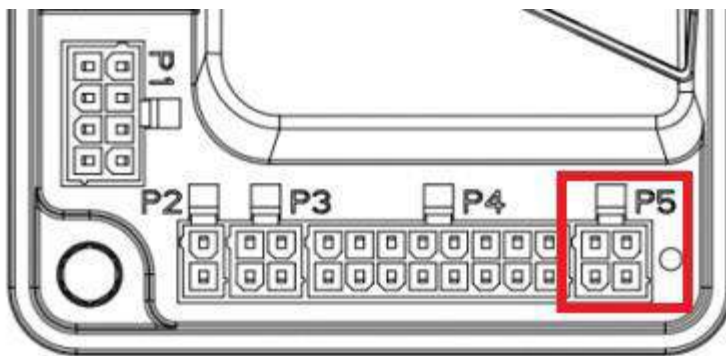

The interface P5 is used for updating the programming of the Main machine controller.

Shop Measurements - UI Controller (EB2)

H1

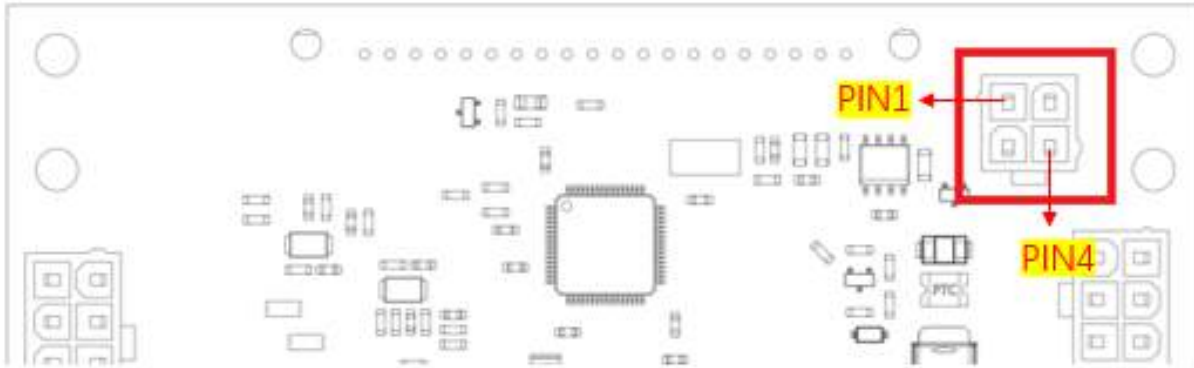

| PIN | Color | Circuit Description | Measured | Comments |
|-----|-------|---------------------|-----------------------------|----------|
| 1 | Blue | CAN_L | 2.38v (on) 0 v (off) | |
| 2 | Black | GND | 0v (on/off) | |
| 3 | Green | CAN_H | 2.57v (on) 0v (off) | |
| 4 | Red | Key_In | 25.23v (on) 0.001v (off) | |

H2

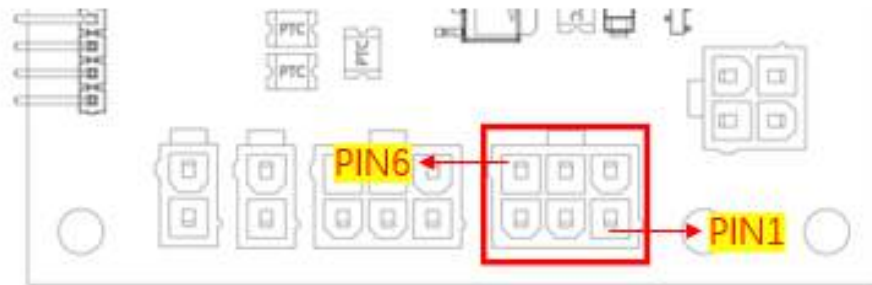

| PIN | Color | Circuit Description | Measured | Comments |
|-----|--------|---------------------------|-----------------------------|----------|
| 1 | Blue | CAN_L for Li-ion battery | 2.195v (on) 0.001v (off) | |
| 2 | Gray | GND | 0.001v (on/off) | |
| 3 | Red | ON/OFF for li-ion battery | 0.01v (on) 25.55 v (off) | |
| 4 | Orange | CAN_H for Li-ion battery | 2.35v (on) 0 v (off) | |
| 5 | N/A | N/A | N/A | N/A |
| 6 | N/A | N/A | N/A | N/A |

H3

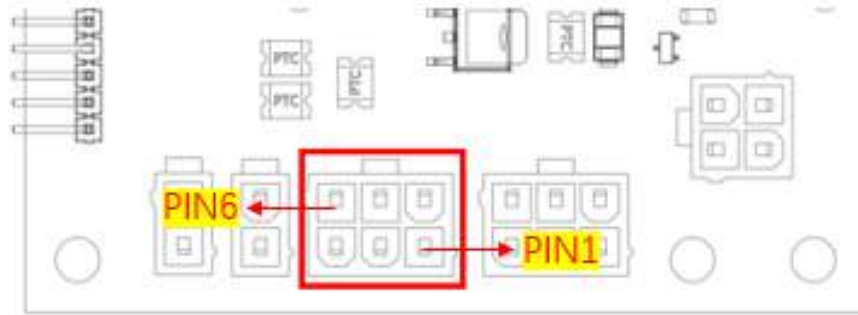

| PIN | Color | Circuit Description | Measured | Comments |
|-----|--------|----------------------------|-----------------------------|----------|
| 1 | Violet | CAN_L for Multicon1 | 2.49v (on) 0.001v (off) | |
| 2 | Black | DGND | 0.006v (on) 0.001v (off) | |
| 3 | Blue | ON/OFF for Multicon1 | 0.169v (on) 0.03v (off) | |
| 4 | Green | CAN_H for Multicon1 | 2.68v (on) 0.001v (off) | |
| 5 | Red | Power supply for Multicon1 | 25.24v (on) 0.001v (off) | |
| 6 | Yellow | BAT+ | 25.51v (on) 25.4v (off) | |

H4

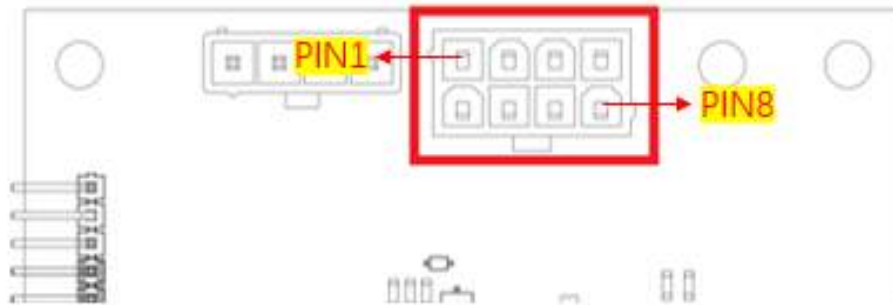

| PIN | Color | Circuit Description | Measured | Comments |
|-----|--------|---|--|----------|
| 1 | Red | +5V power supply for detergent level sensor | 5v | |
| 2 | Yellow | Detergent level sensor signal | 4.74v(no detergent detected) 2.4v(detergent detected) | |
| 4 | Blue | GND | 0.22v | |
| 3 | N/A | N/A | N/A | N/A |
| 5 | N/A | N/A | N/A | N/A |
| 6 | N/A | N/A | N/A | N/A |
| 7 | N/A | N/A | N/A | N/A |
| 8 | N/A | N/A | N/A | N/A |

H5

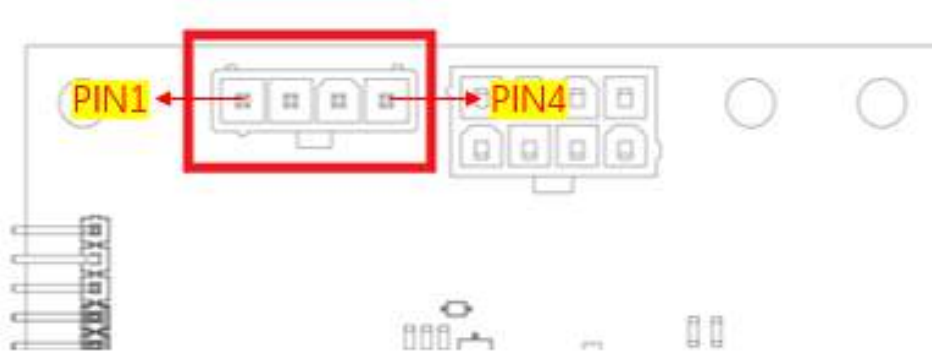

| PIN | Color | Circuit Description | Measured | Comments |
|-----|--------------|---|-------------------------------------|----------|
| 1 | Brown | BAT+ for Li-ion battery charger | 25.5v(charge/ not charge) | |
| 2 | Red | Lead-acid charge signal | 0.04v(charge) 24.9v(not charge) | |
| 3 | Yellow | Li-ion charge signal | 0.004v(charge) 25.5v(not charge) | |
| 4 | Yellow-Black | Lead-acid battery charger communication | 11.23v(charge) 4.30v(not charge) | |

H6



| PIN | Color | Circuit Description | Measured | Comments |
|-----|-------|---------------------|----------|----------|
| 1 | Black | USB power supply - | 25.5v | |
| 2 | Red | USB power supply + | 0.002v | |

H7

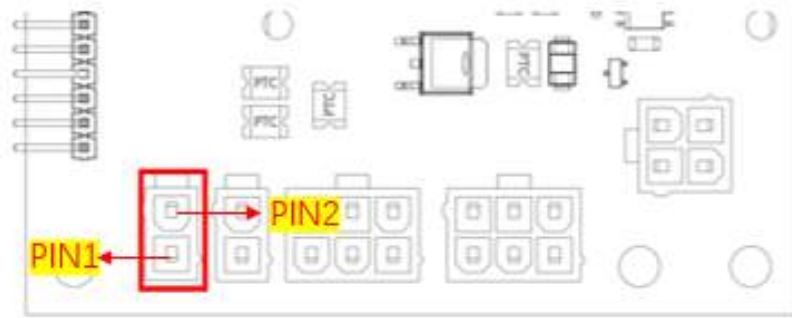

| PIN | Color | Circuit Description | Measured | Comments |
|-----|-------|----------------------------------|----------|----------|
| 1 | N/A | N/A | N/A | N/A |
| 2 | Red | power supply + for UI controller | 25.5v | |

P4

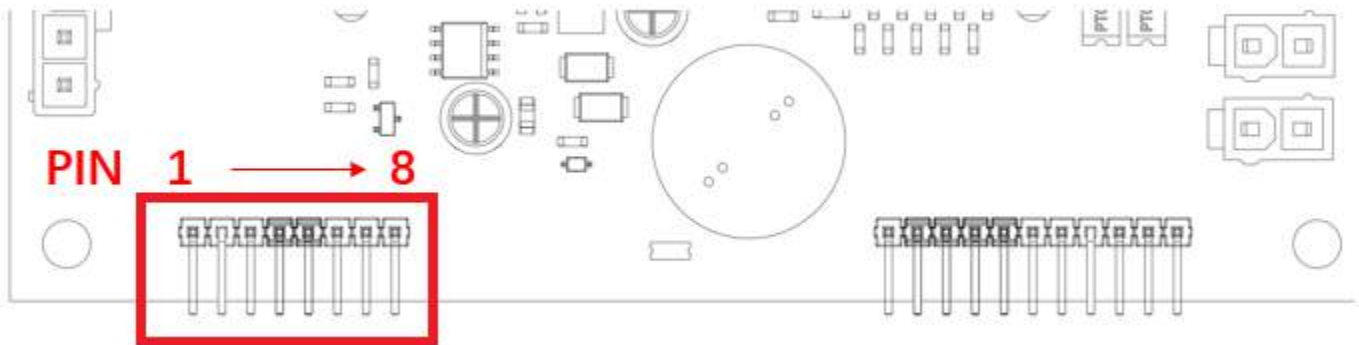

| PIN | Color | Circuit Description | Measured | Comments |
|-----|-------|--|---|----------|
| 1 | | Vcc for LEDs | 3.31v | |
| 2 | | LED1 Green EcoFlex™system switch led indicator | 3.31v(LED off) 1.37v(LED on) | |
| 3 | | LED2 Green Brush/pad-holder release switch warning light | 3.31v(LED off) 1.37v(LED on) | |
| 4 | | LED3 Green Deck lifting/lowering switch led | 3.31v(LED off) 1.37v(LED on) | |
| 5 | | LED3 Red Deck lifting/lowering switch led | 3.31v(LED off) 1.37v(LED on) | |
| 6 | | LED4 Green Vacuum system switch warning light | 3.31v(LED off) 1.37v(LED on) | |
| 7 | | SW11 ON/OFF switch for machine | 3.31v(not pressed) 0.012v(only when pressed) | |
| 8 | | GND | 0.001v | |

P5

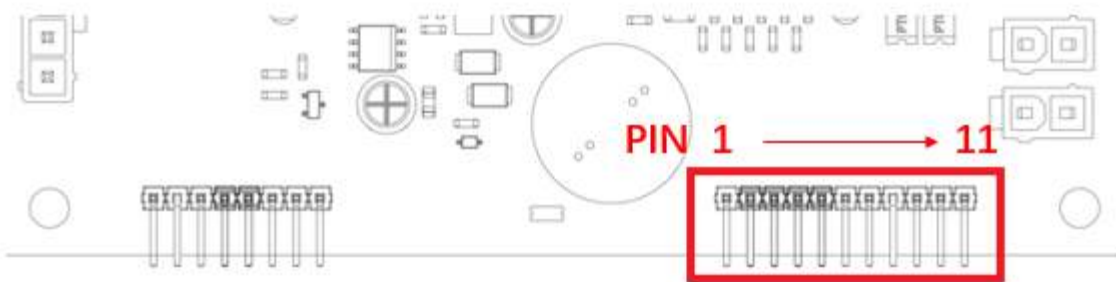

| PIN | Color | Circuit Description | Measured | Comments |
|-----|-------|---|--|----------|
| 1 | | Power supply + | 3.3v | |
| 2 | | Digit 1 button S1 | 0.01v(not pressed) 3.28v(only when press) | |
| 3 | | Digit 2 button S2 | 0.01v(not pressed) 3.28v(only when press) | |
| 4 | | Digit 3 button S3 | 0.01v(not pressed) 3.28v(only when press) | |
| 5 | | Digit 4 button S4 | 0.01v(not pressed) 3.28v(only when press) | |
| 6 | | Vacuum system switch(S5) | 0.01v(not pressed) 3.28v(only when press) | |
| 7 | | Brush-holder deck lifting/lowering switch(S6) | 0.01v(not pressed) 3.28v(only when press) | |
| 8 | | EcoFlex™system switch(S7) | 0.01v(not pressed) 3.28v(only when press) | |
| 9 | | Washing detergent flow control switch(S8) | 0.01v(not pressed) 3.28v(only when press) | |
| 10 | | Solution flow control switch(S9) | 0.01v(not pressed) 3.28v(only when press) | |
| 11 | | Brush/pad-holder release switch(S10) | 0.01v(not pressed) 3.28v(only when press) | |

10 Chassis System

Chassis (main parts)

The chassis function is primarily performed by the solution tank, the support housings for the wheels and working mechanisms are integrated in the drive motor and the rear frame.

- Chassis
- Brush deck lifting levers
- Drive wheel and motor
- Squeegee lifting/lowering system

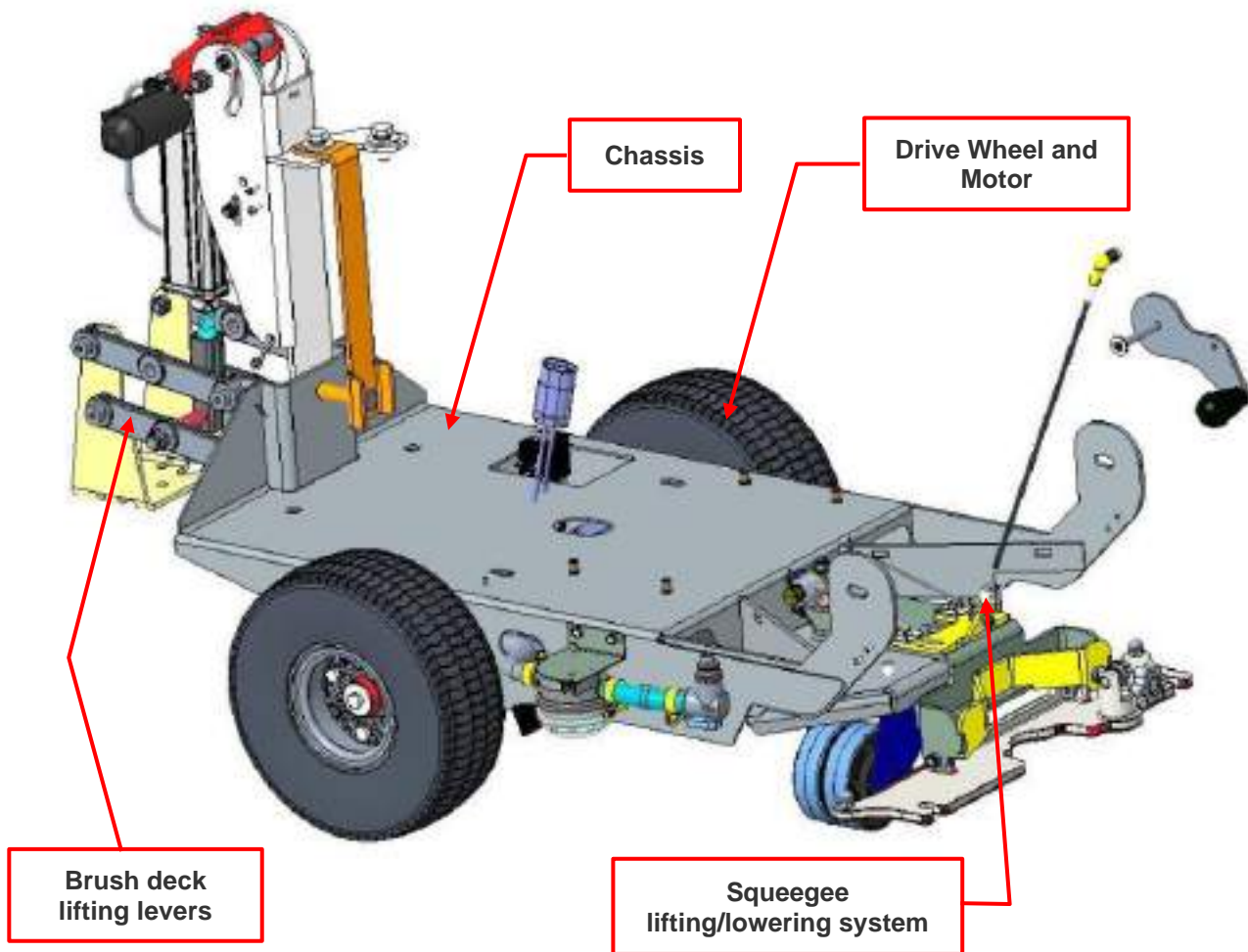

20 Drive system

Functional Description

Machine movement is provided by the drive motor (M3).

The drive motor (M3) also functions as the main support of the machine, and is composed of an electric motor, the reduction unit with differential and the drive wheels.

The operator regulates the transfer speed, the working speed and reverse via the paddle box, which is connected directly to the maximum speed potentiometer (RV1) and the speed potentiometer (RV2). Forward/reverse gear paddle is connected to the speed potentiometer (RV2), and by pressing or pulling it, the machine will move forward or reverse accordingly; and the forward and reverse speed is controlled by the force that the operator uses to press or pull the gear paddle. The maximum speed adjuster is connected to the maximum speed potentiometer (RV1), and by turning it, the maximum speed of the machine can be adjusted.

The Main machine controller (EB1) checks that the paddle is not pressed when the machine is started; if it is, an alarm is generated (see section “Main Machine Controller (EB1) and UI Controller (EB2) Alarm Codes” in the “Control System” chapter) and the drive system is inhibited.

Once the paddle is returned to the rest position, the alarm will stop automatically (without the need to turn the machine on and off).

When the paddle is pressed, the Main machine controller (EB1) supplies a voltage to the motor proportional to the position of the paddle itself. The acceleration ramps and maximum speed can be set via the corresponding parameters (see section “Display, Machine Settings Screen” in the “Control System” chapter).

Wiring Diagram

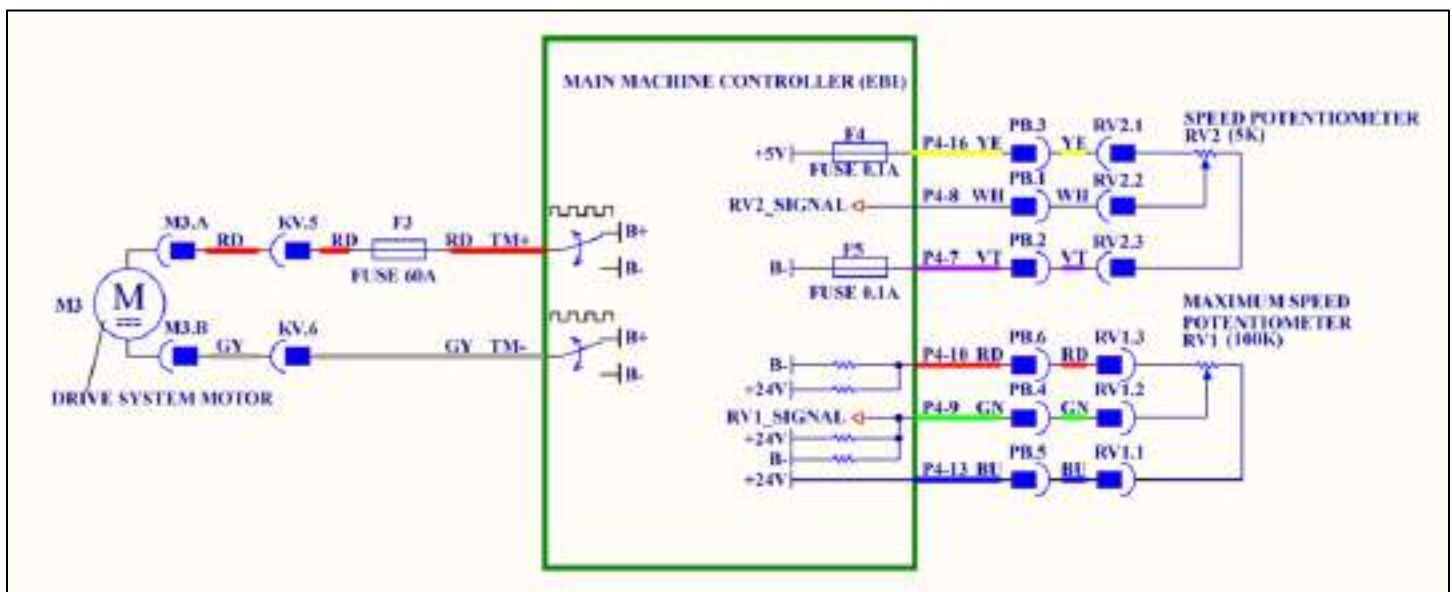

Component Locations

- Forward/reverse gear paddle
- Front driving wheels
- Drive motor
- Main machine controller (EB1)
- Maximum speed adjuster (RV1)
- Castor
- Drive motor fuse (F3)

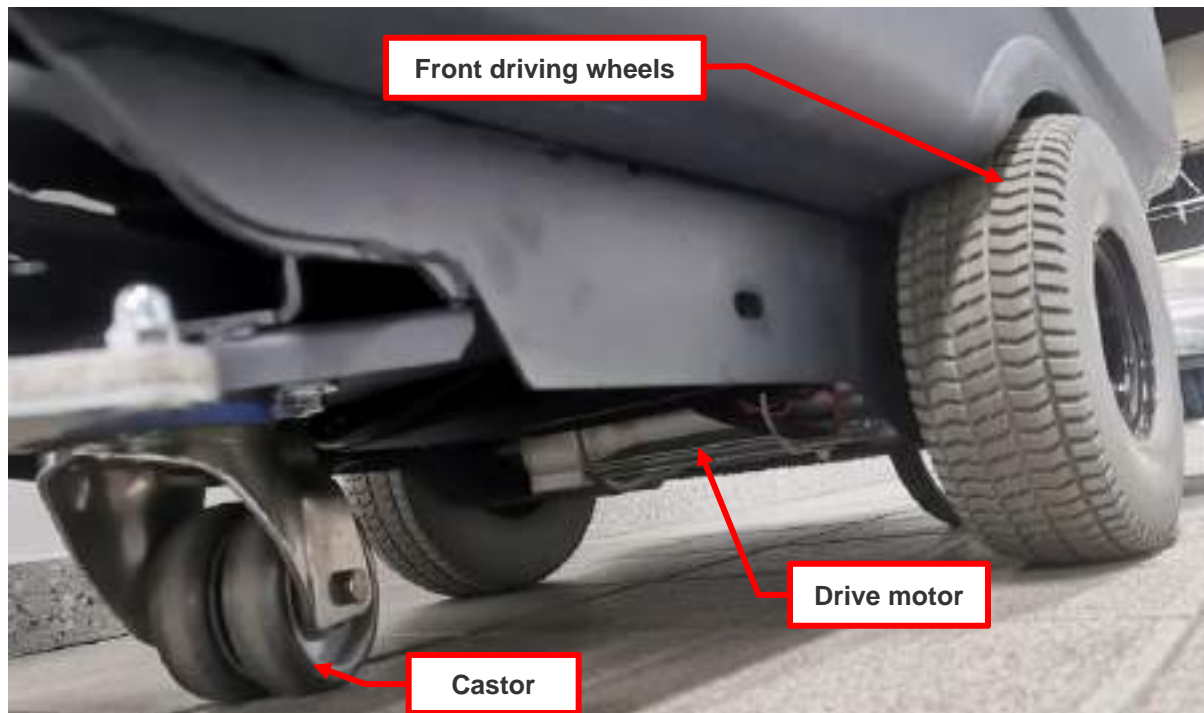
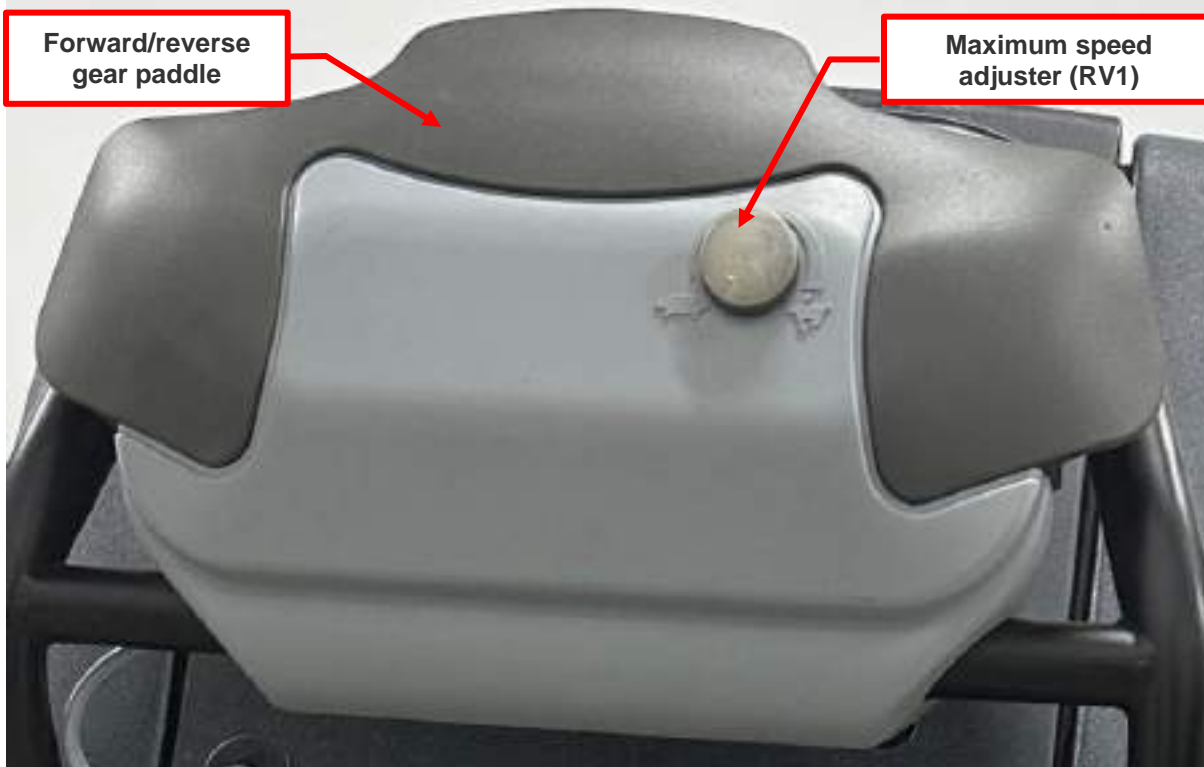

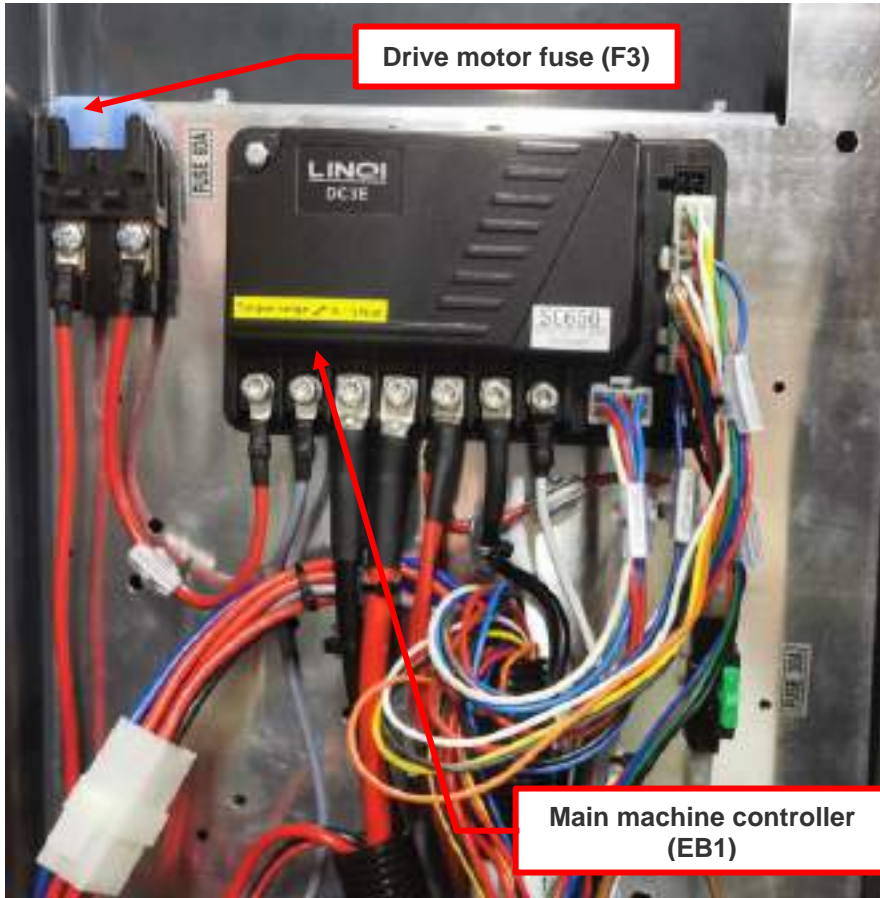

Maintenance and Adjustment

Drive Motor Carbon Brush Check/Replacement

1. Drive the machine to the appointed disposal area and empty the recovery tank with the hose.
2. Place the machine on a hoisting system (if available). Otherwise, drive the machine on a level floor.
3. Switch off the machine.
4. Disconnect the battery connector.
5. Remove the brush/pad-holder deck.
6. Operating on the right side of the machine, clean the drive motor (A) in the area of the covers (B).
7. Remove the nuts (C) and cover (B). Mark the drive motor (A) and its cover (B) with a line before removing the cover (B) for precise alignment during installation.
8. Check the carbon brushes (D) for wear. Replace the carbon brushes when: the contact with the motor armature is insufficient, the carbon brushes are worn, the carbon brush contact surface is not integral, the thrust spring is broken, etc.
9. If necessary, replace the carbon brushes according to the following procedure:
10. Disengage the spring (E) and terminal (F) and remove the carbon brush (D) from its housing. Replace the carbon brushes as an assembly.
11. Assemble in the reverse order of disassembly and note the following:
If necessary, lay the machine on its left side.
Press the carbon brushes (D) into the slots and use the springs (E) to hold the carbon brushes (D). Then pull the rotor (G) out for 10-15mm, align the marked line of drive motor (A) and its cover (B) to install the cover (B) on the rotor (G), gently push the carbon brushes (D) through the gap between the drive motor (A) and cover (B) to reset the carbon brushes (D). Finally fix the cover (B) with nuts (C).

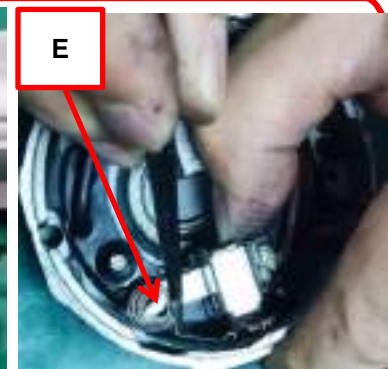
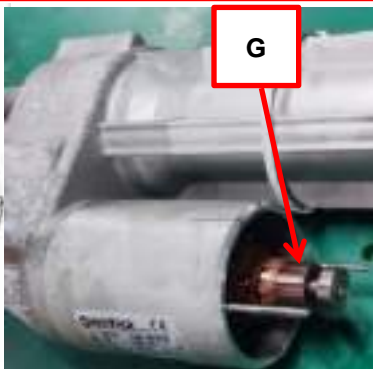
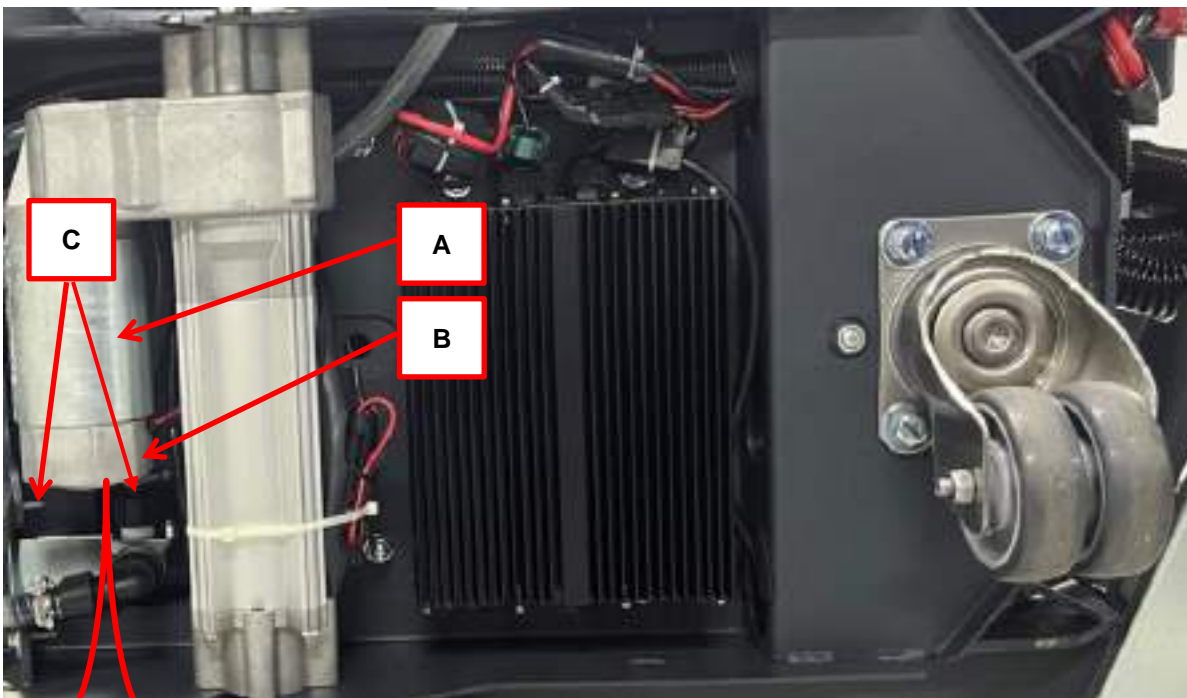

Troubleshooting

| Trouble | Possible Causes | Remedy |
|---------------------------|--|---|
| The machine does not move | Battery voltage too low | Charge the battery |
| | Drive motor fuse (F3) broken | Replace |
| | The maximum speed potentiometer (RV1) is broken | Replace |
| | The speed potentiometer (RV2) is broken | Replace |
| | Maximum speed adjuster incorrectly regulated or broken | Replace |
| | Main machine controller (EB1) faulty | Replace |
| | Wiring damaged | Check all connections inside the electrical component compartment, including those of the Main machine controller (EB1) |
| | Drive motor (M3) carbon brushes worn | Replace |
| | Drive motor (M3) faulty | Replace |

Drive Motor Current Draw Test



WARNING: This procedure must be performed by qualified personnel only and with the help of an assistant.

1. Drive the machine on a level floor.
2. Use a suitable chock to raise one side of the machine approximately 2cm from the floor and allow one drive wheel to turn freely.
3. Lift the recovery tank.



WARNING: Pay attention to the rotation of the driving wheel when performing the following steps.

4. Apply the amp clamp on the positive cable (red) of the battery wiring harness.
5. Turn on the machine and activate forward drive at maximum speed via the paddle, checking that the current draw falls within the following values:
 - Between 0 and 12A at 24V for AMER drive motor
6. Release the paddle.
7. Switch off the machine and remove the amperometric clamp.
8. If the amperage is higher, perform the following procedures to detect and correct the abnormal amperage:
 - Check if there is dust or debris preventing the wheel rotation.
 - If necessary, disassemble the motor (see the procedure in the relevant paragraph), and check the condition of all its components.
9. If the above-mentioned procedures do not lead to a correct amperage, the motor must be replaced (see the procedure in the relevant paragraph).

Removal and Installation

Speed Potentiometer (RV2)

Removal

1. Drive the machine on a level floor, disconnect the battery connector.
2. Follow the step 4~5 of UI Controller Removal in 04 Control System to take out the paddle box.
3. Disconnect the connection (A) and unscrew the nut (B), then completely remove the paddle box.
4. Unscrew the 4 screws (C) and take out the paddle box front cover.
5. Unscrew the 2 screws (D), then push the paddle box rear cover (E) outwards to take the fixing bracket (F) out.
6. Unscrew the 2 screws (G).
7. Cut cable tie (H), and disconnect the connection (I).
8. Remove the potentiometer (RV2) (J).

Installation

9. Assemble the components in the reverse order of disassembly.

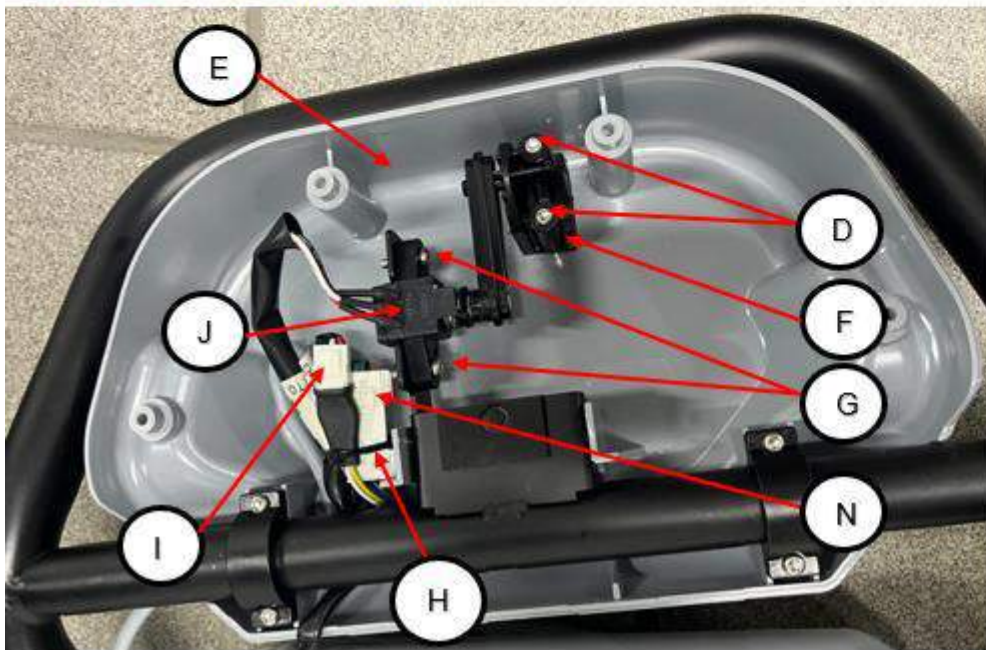
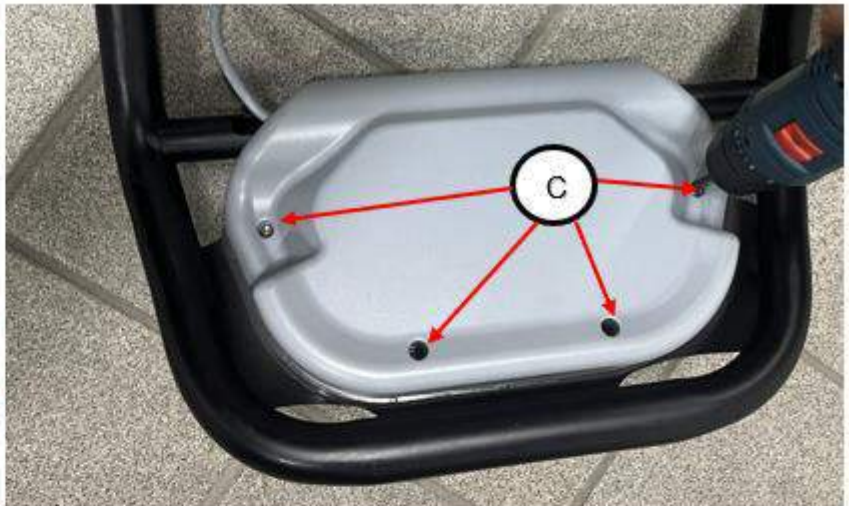
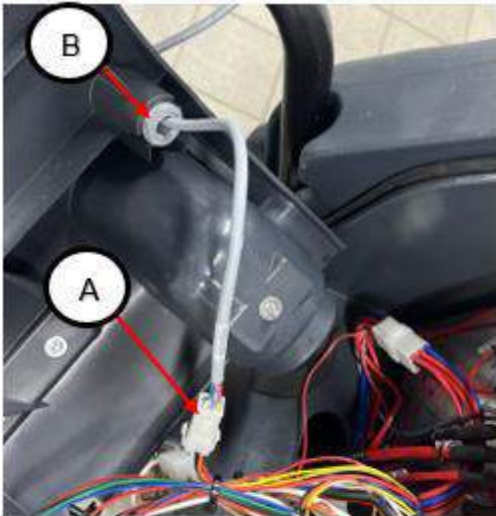

Speed Potentiometer (RV1)

Removal

1. Perform steps 1 to 4 in “Speed Potentiometer (RV2) Removal” section.
2. Unscrew the screw inside the hole of knob (K) and take the knob (K) out.
3. Unscrew the nut (L), and unscrew the screw (M) on the back side of the paddle box front cover.
4. Cut cable tie (H), and disconnect the connection (N) on the paddle box rear cover, then remove the potentiometer (RV1) (O).

Installation

5. Assemble the components in the reverse order of disassembly.

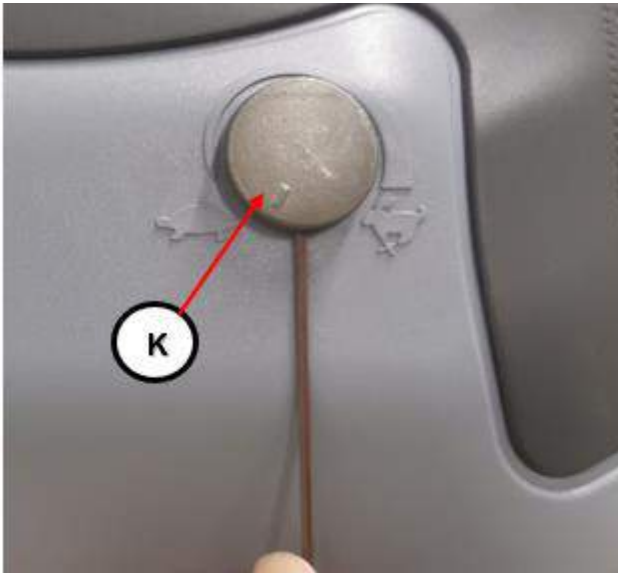

Drive Motor

Removal

1. If the recovery tank and/or solution tank contains recovery water:
 - Drive the machine to the appointed disposal area.
 - Switch off the machine.
 - Empty the recovery tank with the hose.
 - Empty the solution/clean water tank with the hose.
2. Remove the squeegee (see the procedure in the relevant paragraph).
3. Remove the batteries (see the procedure in the relevant paragraph).
4. Prepare a hoisting system on which the machine is to be laid on one side. Place a panel on the hoisting system to avoid damaging the machine.
5. With the help of an assistant, tilt the machine on one side and lay it on the panel.
6. Remove the screws (C) and the wheels (D) and recover the keys (E) and Seeger rings (I).
7. Remove the screws (F) on both sides.
8. Disconnect the connectors (G) of the drive motor.
9. Remove the motor-differential (J).

Installation

10. Assemble the components in the reverse order of disassembly.

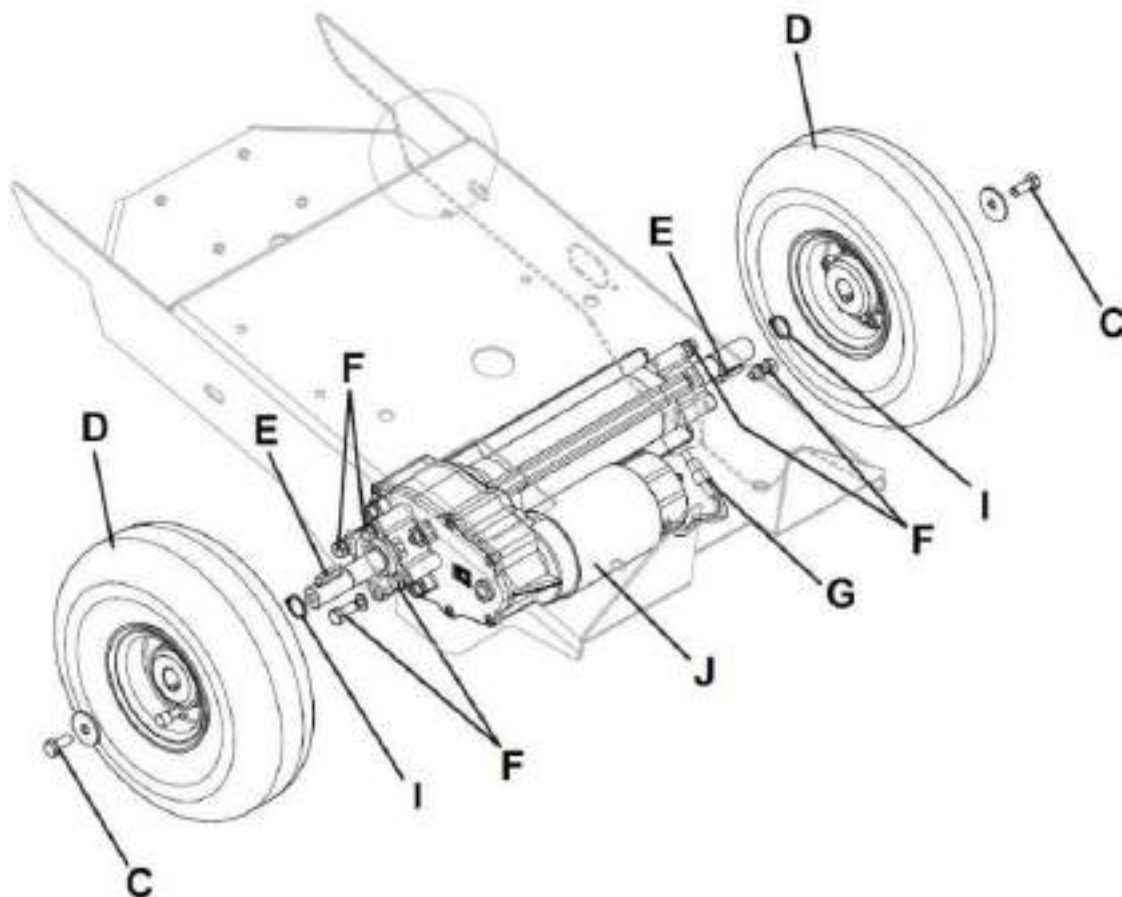

Specifications

| Description / Model | | SC650 66D | SC650 71D | SC650 85D | SC650 71C |
|--|--------------------|-----------------|-----------|-----------|-----------|
| Driving wheel diameter | | 267 mm | | | |
| Driving wheel specific pressure on the floor (*) N/mm ² | | 0.45 | 0.45 | 0.45 | 0.48 |
| Castor diameter | | 100 mm | | | |
| Castor specific pressure on the floor (*) N/mm ² | | 1.03 | 1.03 | 0.91 | 0.91 |
| Drive speed (variable) | | 0 - 5.6 km/h | | | |
| Maximum gradient when working | | 2% (1°) | | | |
| Electric wheel drive unit technical data | Power | 0.27 hp (200 W) | | | |
| | Voltage | 24V | | | |
| | Transmission ratio | 1/26 | | | |
| | Protection class | IP44 | | | |
| | Insulation class | F | | | |

(*) Machines have been tested under the following conditions:

- Battery normal size
- Maximum brush and squeegee size
- Full detergent tank
- Optional equipment installed.
- Wheel weight checked.
- Print on the floor checked on cement for each single wheel.
- Result expressed as maximum value for both front wheel and castor.

24 Electrical System

Functional Description

1. Machine with lead acid battery:

The lead acid batteries (1 x 24V or 2 x 12V or 4 x 6V in series) are connected in series by the cables.

The battery charger (LA-CH) is connected to the machine by two connectors (C2) (power connection to the batteries) and C3 (3-way signal connection).

The brown and blue cables (1 and 2 of connector C3) are short circuited inside the battery charger LA-CH when this is not connected to the machine. If this connection is not made, all machine functions are disabled. If the optional battery charger has not been installed, the relevant bridge must be used on connector C3.

The green cable (terminal 3 of connector C3) is the data cable between controller (EB2) and battery charger (LA-CH). This connection allows the battery charger charging curve to be set directly from the machine UI controller and to view the operational state of the battery charger during charging directly on the UI controller display.

2. Machine with li-ion battery:

The li-ion batteries (2 x 24V or 3 x 24V in parallel) are connected in parallel by the cables.

The Li-ion battery charger (LI-CH) is connected to the machine by two connectors (C1) (power connection to the batteries) and C5 (2-way signal connection).

The brown and yellow cables (1 and 2 of connector C5) are short circuited inside the battery charger LI-CH when this is not connected to the machine. If this connection is not made, all machine functions are disabled. If the optional battery charger has not been installed, the relevant bridge must be used on connector C5.

The pink and blue cables (CAN_L) and the white and orange cables (CAN_H) are the data cables between the controller (EB2) and the Li-ion battery charger (LI-CH) and the li-ion battery (LI-BAT).

This connection allows the Li-ion battery charger charging curve to be set directly from the machine UI controller and to view the operational state of the battery charger during charging directly on the UI controller display.

To prolong battery life, the machine has low voltage cut-off function. When the battery voltage is reduced to a certain value, the functions of the brush motor, the vacuum motor and the drive motor will fail.

Different battery type settings are of different low voltage cut-off threshold. See corresponding voltage values in the table below. If the battery type is changed, the charger battery type must be set accordingly. See relevant procedures in section "Maintenance and Adjustment".

Lead Acid Battery

| State | Thresholds from transition (V > , tolerance ± 0.1) | | |
|-------|---|------|--------|
| | WET | GEL | Nexsys |
| D | 20,4 | 21,6 | 22.8 |
| E | 19,4 | 20,6 | 22.6 |
| F | 18,4 | 19,6 | 22.4 |

Once the status D is reached, the BRUSHES function is automatically deactivated after a delay of 5 seconds.

If status E is reached, the SUCTION function is also automatically deactivated.

If status F is reached, the TRACTION function is also automatically deactivated.

Li-ion Battery

| Level | SOC % | Display | Action |
|-------|---------------|-------------------|-----------|
| F | 22 V – 21.5 V | 0/3 bars blinking | brush off |
| G | 21.5 V – 21 V | 0/3 bars blinking | vac off |
| H | < 21 V | 0/3 bars blinking | drive off |

Once the status F is reached, the BRUSHES function is automatically deactivated after a delay of 5 seconds.

If status G is reached, the SUCTION function is also automatically deactivated.

If status H is reached, the TRACTION function is also automatically deactivated.

Wiring Diagram (Lead-acid)

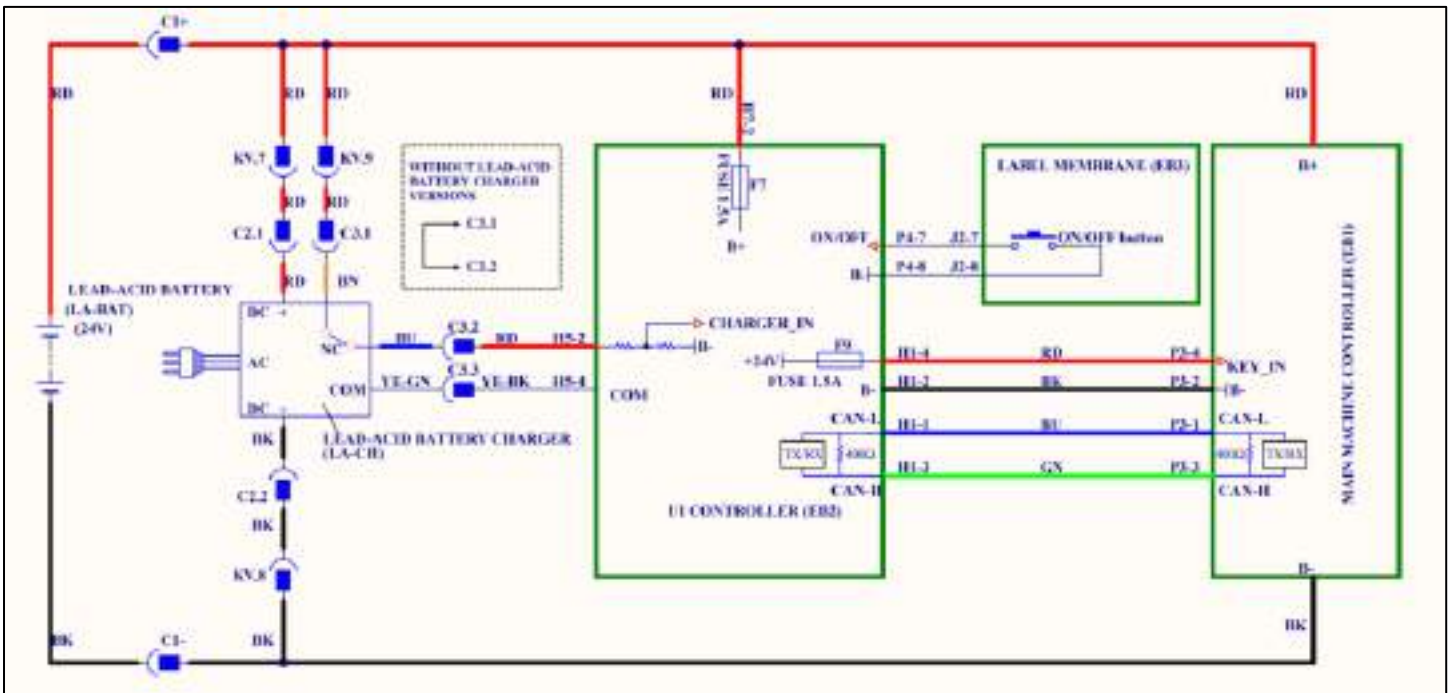

Figure 1

Wiring Diagram (Li-ion)

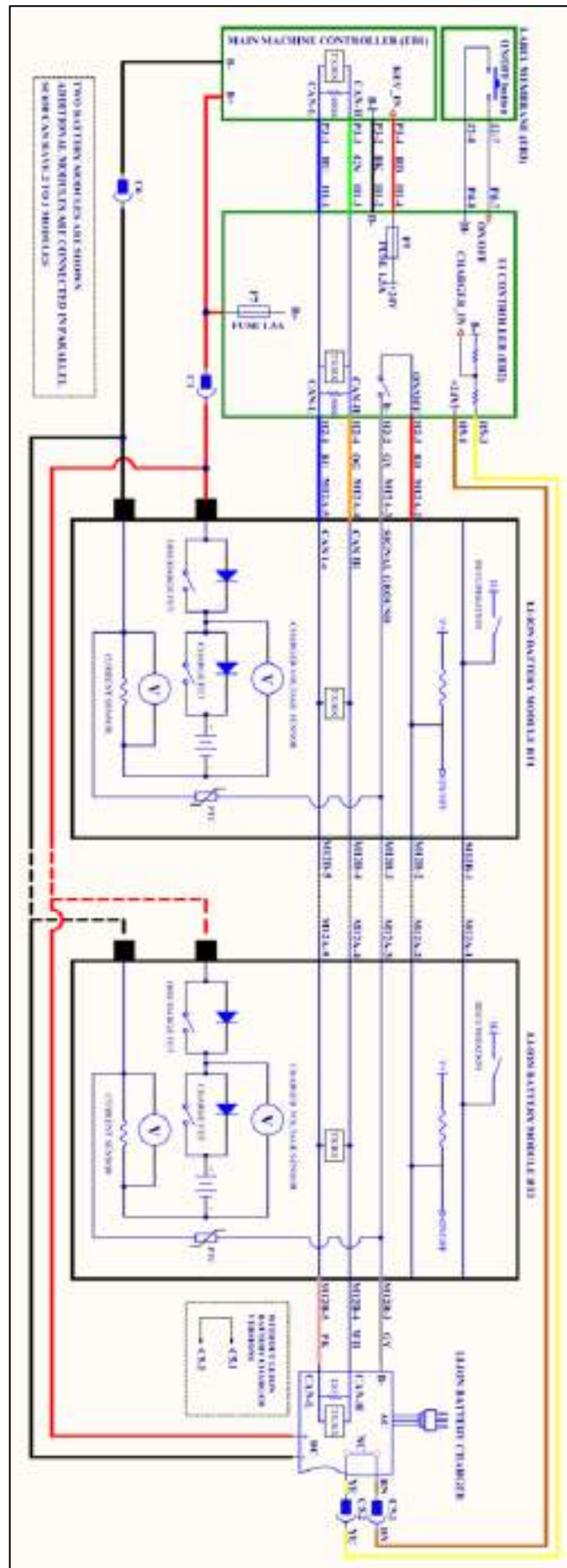

Figure 2

Component Locations (Lead-acid)

- Main machine controller (EB1)
- UI controller (EB2)
- Lead-acid battery charger (LA-CH)
- Battery connections
- Lead-acid battery (LA-BAT)
- Battery connector (C1)

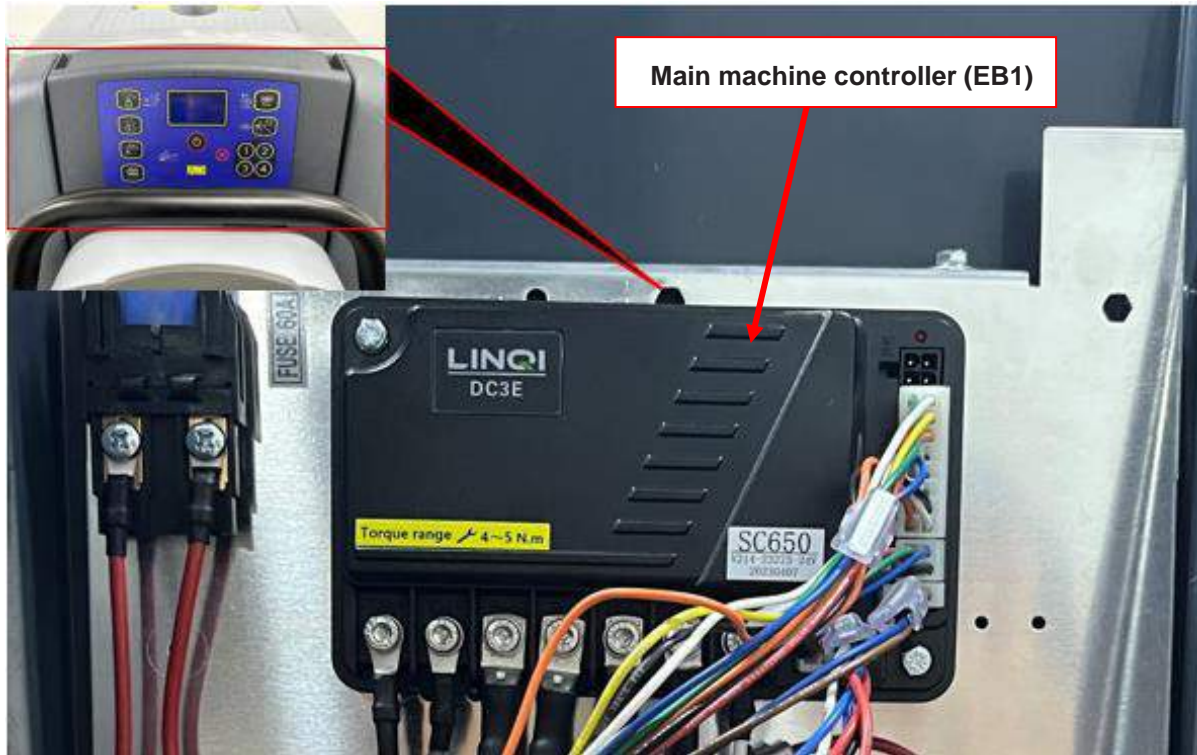

Figure 3

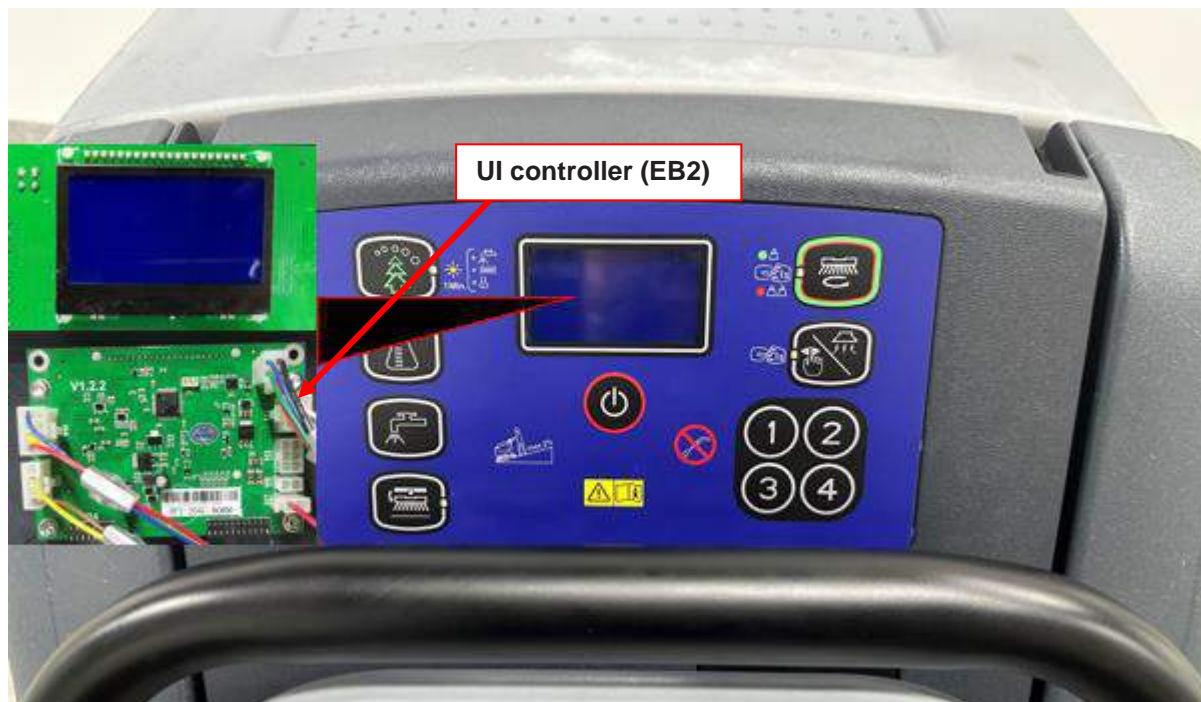

Figure 4

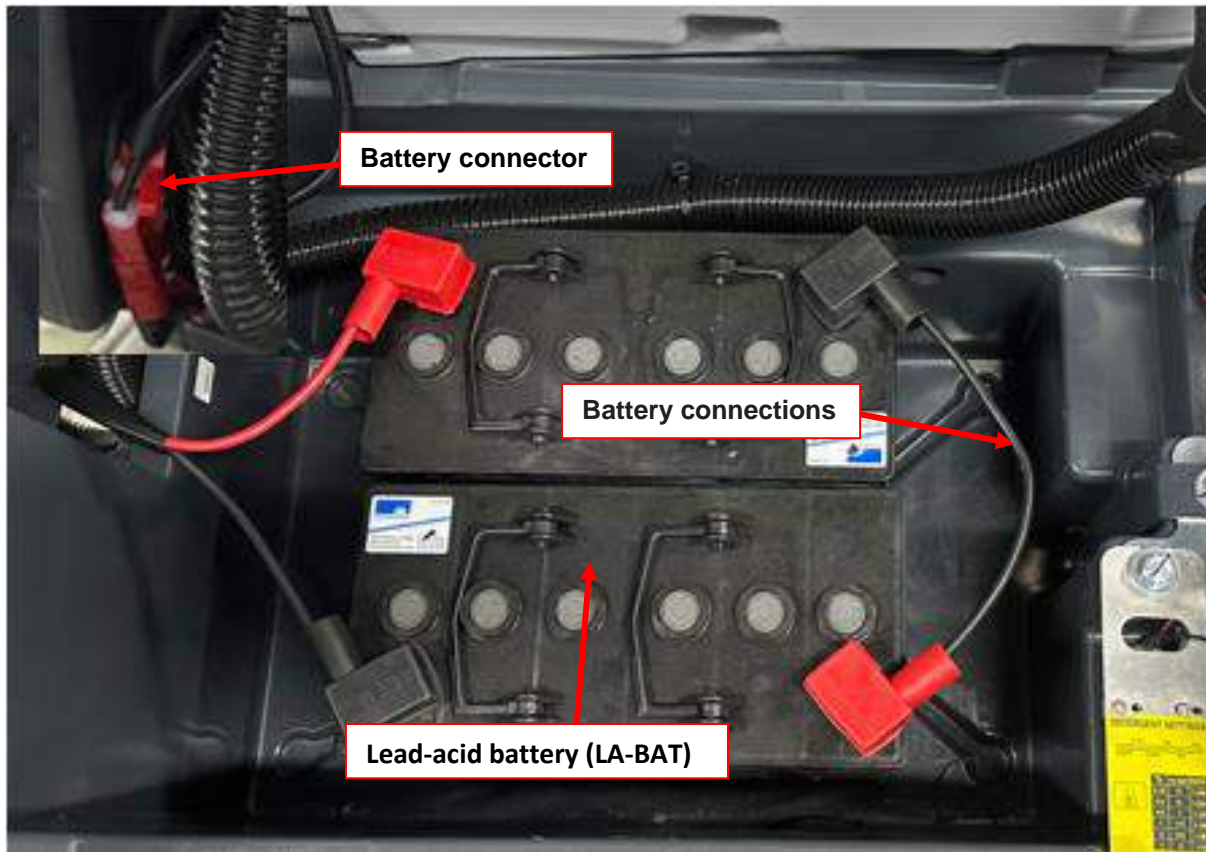

Figure 5

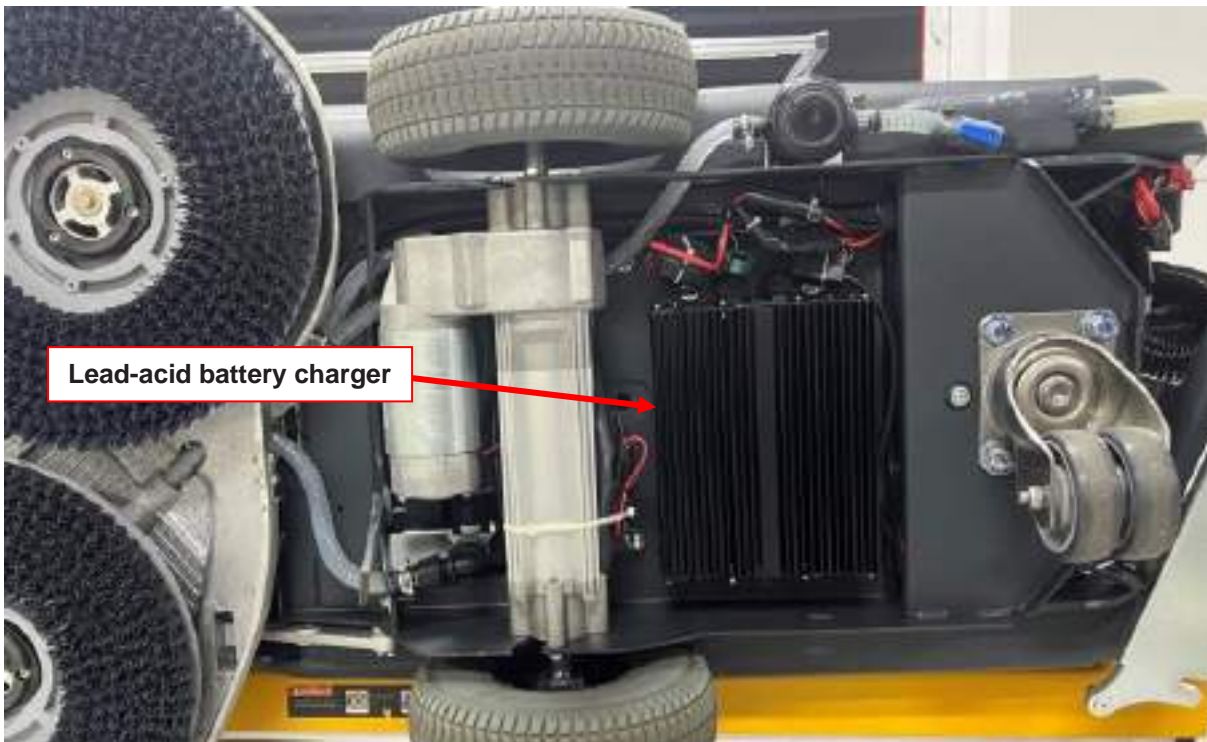

Figure 6

Component Locations (Li-ion)

- Main machine controller (EB1)
- UI controller (EB2)
- Li-ion battery charger (LI-CH)
- Battery connections
- Li-ion battery (LI-BAT)
- Battery connector (C1)

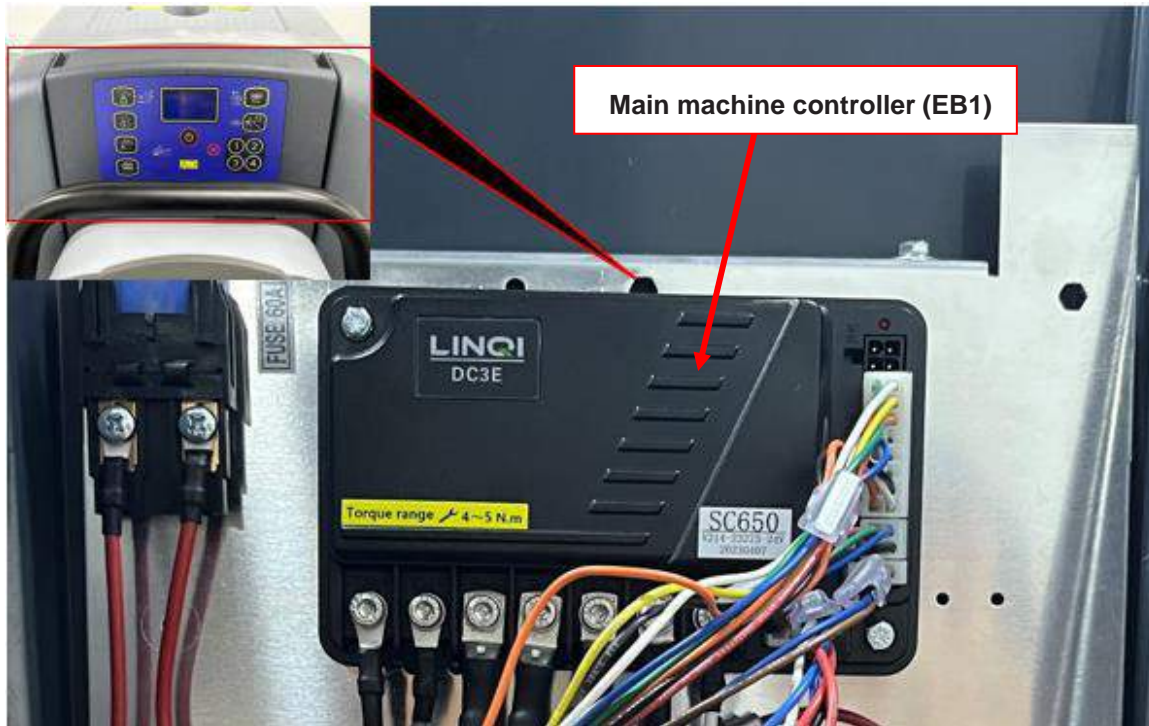

Figure 7



Figure 8

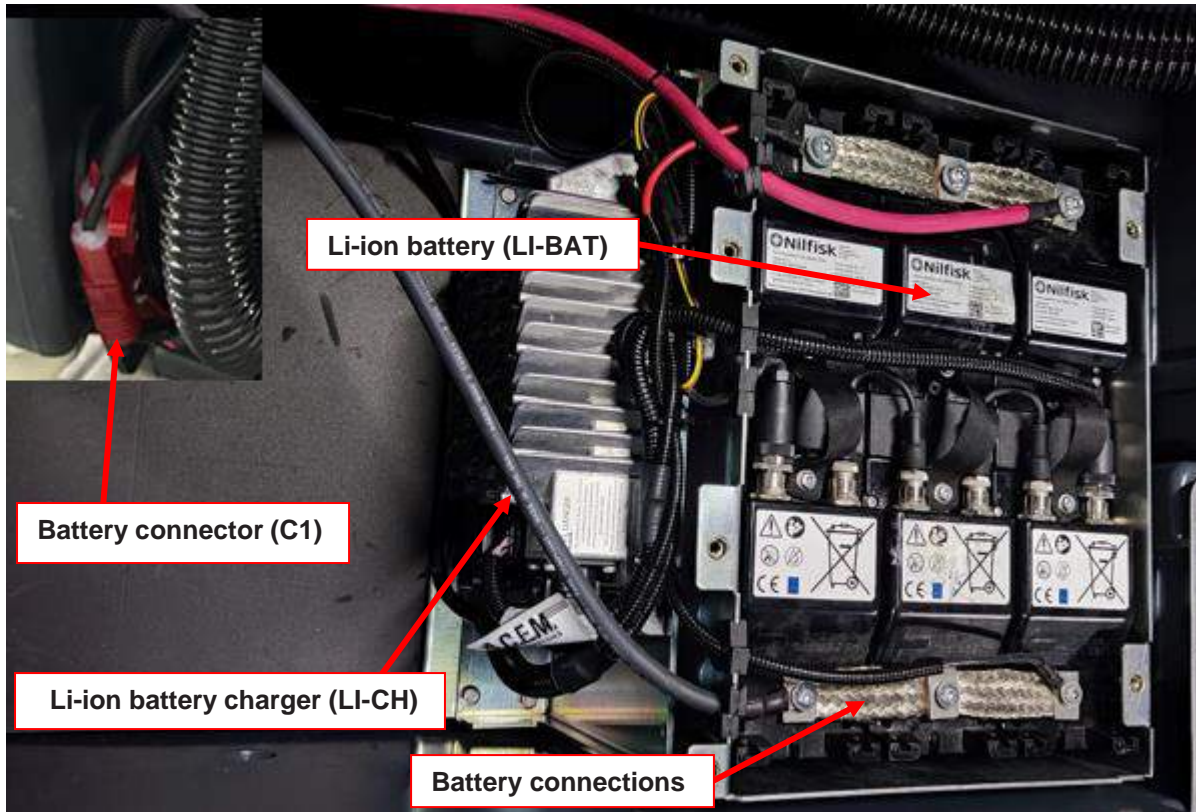

Figure 9

Maintenance and Adjustments

Setting the Installed Battery Type

Set the machine and the on-board battery charger (where fitted) on the basis of the type of battery to be installed by modifying the BAT parameter as indicated.









1. Press and hold the One-Touch button  or  and the vacuum button  simultaneously.
2. Press and release the switch .
3. Release the One-Touch button  or  and the vacuum button  after the logo disappears on the screen.
4. Enter the supervisor password 4444 to access the main screen (Figure 10) of the multifunction display.
5. Press the One-Touch button  or  to continue to the machine settings screen (Figure 11)





Figure 10





Figure 11



6. Press the vacuum button  until you reach the BAT parameter.

| Modifiable Parameters | | | | |
|-----------------------|------------------------|------------|-----------------|------------|
| Code | Description | Min. Value | Factory Setting | Max. Value |
| BAT | Installed battery type | 1 | 3 | 8 |

7. Press the One-Touch button  or  to select the option “+” or “-”.
8. Press the vacuum button  to modify the value of the BAT parameter as per the following table:

| Code BAT | | |
|----------|------------------------|--|
| Value | Installed battery type | |
| 1 | WET | Wet cell batteries |
| 2 | GEL-AGM | Generic GEL or AGM batteries |
| 3 | GEL EXIDE® type | EXIDE®/SONNENSHINE brand GEL batteries |
| 4 | WET | Wet cell batteries |
| 5 | GEL-AGM | Generic GEL or AGM batteries |
| 6 | GEL EXIDE® type | EXIDE®/SONNENSHINE brand GEL batteries |
| 7 | NEXSYS | TPPL batteries |
| 8 | LI-ION | VARTA brand LI-ION batteries |

9. Press the One-Touch button  or  to move the arrow to “SAVE&NEXT” and press the vacuum button  to save and move to the next parameter.

10. Press the One-Touch button  or  to move the arrow to “EXIT” and press the vacuum button  to return to the main screen.

Battery Installation

1. Turn off the machine.
2. Disconnect the battery connector.
3. Lift the recovery tank cover and check that it is empty; if not, empty it using the drain hose.
4. Grasp the handle and carefully lift the recovery tank.
5. The machine is supplied with cables suitable to install the batteries.
6. Carefully lift the batteries until the relevant compartment, then place them properly.
7. Route and install the battery cables as shown in the diagram (Figure 12 and 13), connect the negative cables first, then connect the positive cables. For Lead-acid batteries, carefully tighten the nut on each battery terminal. And for Li-ion batteries, carefully tighten the screw on each battery terminal (M6 screw with 3.9Nm and M8 screw with 9Nm). Please refer to "Lithium Ion Battery Module Service Manual" (56043180) and "Installation Instruction for SC650 LITHIUM ION W/ICC STANDARD KIT" (55943396) for details.
8. Place the protection cap on each terminal, then connect the battery connector.
9. Perform a complete battery charging cycle.



Note: When Li-ion batteries in the machine need to be replaced with Lead acid batteries, remember to disconnect the Li-ion batteries connectors H2 and H5 on EB2 before installing Lead acid batteries.

The machine can be equipped with:

1. Lead-acid batteries
 - one 24 V battery
 - two 12 V batteries
 - four 6 V batteries

connected according to the diagram shown in Figure 12.

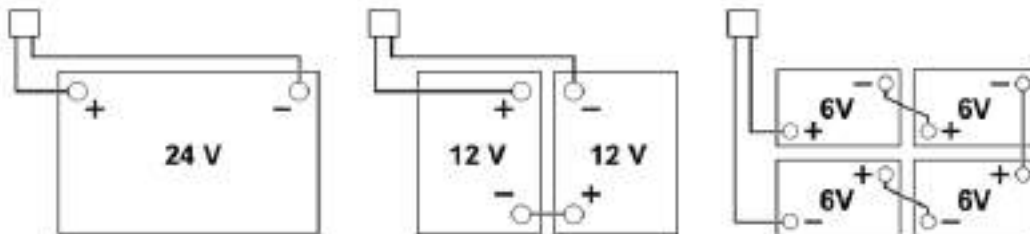

Figure 12

2. Li-ion batteries
 - two 24 V batteries
 - three 24 V batteries

connected according to the diagram shown in Figure 13.

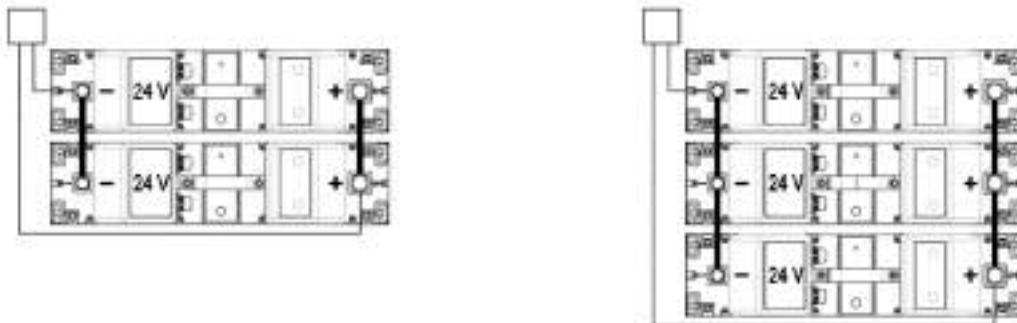

Figure 13

Battery Charging



Note: Fully charge the batteries at the end of each shift. If during operation there is only one flashing segment displayed in the battery symbol, stop using the machine and fully recharge the batteries. Keeping the batteries charged make their life last longer.



Caution! When the batteries are discharged, charge them as soon as possible, as that condition makes their life shorter. Check for battery charge at least once a week.



Caution! If the machine is not equipped with on-board battery charger, choose an external battery charger suitable for the type of batteries installed.



Warning! When using lead (WET) batteries, battery charging produces highly explosive hydrogen gas. Charge the batteries in well-ventilated areas and away from naked flames. Do not smoke while charging the batteries. Keep the recovery tank raised until the battery charging cycle is over.



Warning! Pay close attention when charging WET CELL batteries, as there may be battery fluid leakages. The battery fluid is corrosive. If it contacts with skin or eyes, rinse thoroughly with water and consult a physician.

1. (For WET CELL batteries only) Check the level of electrolyte inside the batteries. If necessary, unscrew the caps and top up.
2. When the correct level is restored, close the caps and clean the tops of the batteries.

Charging the Batteries with an External Battery Charger

1. Check that the external battery charger is suitable by referring to the relevant Manual. The battery charger voltage rating must be 24V.
2. Disconnect the battery connector and connect it to the external battery charger.
3. Connect the battery charger to the electrical mains.
4. After charging, disconnect the battery charger from the electrical mains and from the battery red connector.
5. Connect the battery connector to the machine.
6. Carefully lower the recovery tank.

Charging the Batteries with battery charger installed on the machine

1. Plug the battery charger into the mains electricity supply (the mains voltage and frequency must be compatible with the battery charger values shown on the machine serial number plate).



Note: When the battery charger is connected to the electrical mains, all machine functions are automatically cut off.

2. When the first or second segment from the left in the battery symbol is flashing, this means that the battery charger is charging the batteries.
3. When the third segment from the left in the battery symbol is flashing, this means that the battery charger is finishing the battery charging cycle.
4. When all segments of the battery symbol are steadily lit, the battery charging cycle is complete.
5. Disconnect the battery charger plug from the mains and place it in its holder.
6. Carefully lower the recovery tank.



Note: For further information about the operation of the battery charger, see the relevant Manual.

Checking/Replacing Fuses

1. Refer to step 1-6 in “UI Controller (EB2) and Label membrane (EB3) Removal/Replacement”
2. After disconnecting the connectors from the UI controller, remove the control panel.
3. Check/replace the following fuses (Figure 14):
 - (A) Brush deck fuse F1: (50 A)
 - (B) Vacuum system fuse F2: (30 A)
 - (C) Drive system fuse F3: (60 A)

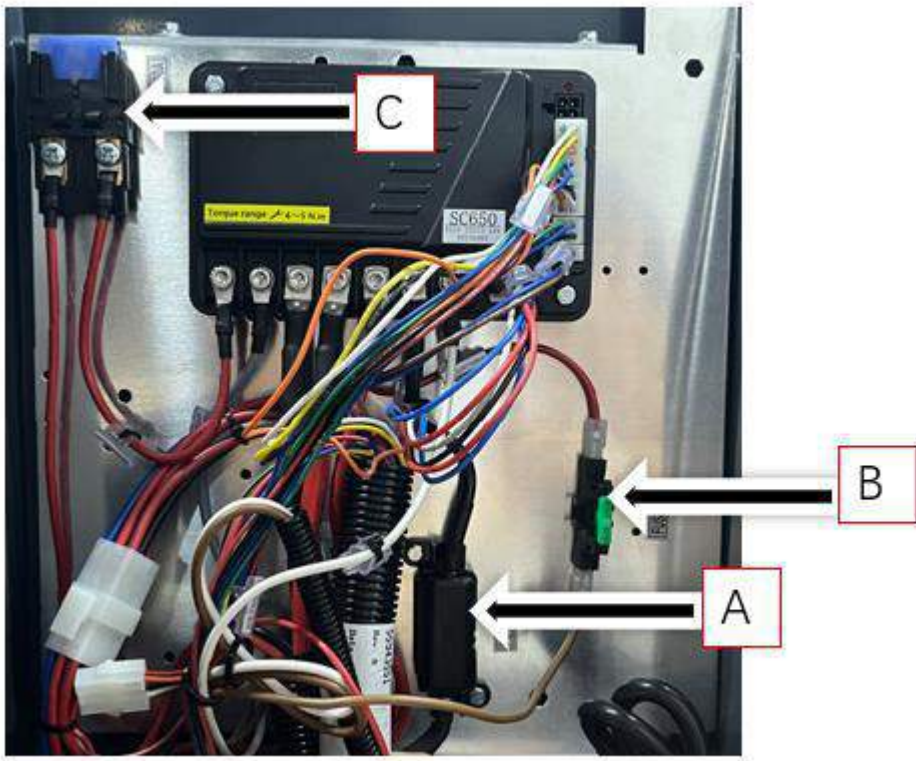

Figure 14

Troubleshooting

See the other chapters for previously provided instructions for other electrical system components.

| Trouble | Possible Causes | Remedy |
|----------------------------|---|---|
| The machine is not working | Batteries flat or connections faulty | Charge the batteries or clean the connections |
| | The batteries are broken | Check the battery no-load voltage |
| | The battery charger is broken | Replace |
| | The wiring harness is cut or pressed or short circuited | Repair |



Note:

A damage to the battery charger or its connections can prevent the machine from operating properly.

Specifications

| Description | | Value |
|--|--------------------|-----------------------------------|
| Battery compartment size (length x width x height) | | 375 x 355 x 615 mm |
| Standard batteries | | (4 x 6 V) 180 Ah@5h |
| Standard battery run time (capacity) | | 3.5 - 4 hours |
| Battery charger | Model | 24V 25A |
| | Input voltage | 230V 10% 50/60Hz(MAX CURRENT 10A) |
| | Charging procedure | by microprocessor |
| | Efficiency | > 88% |
| | IP grade | IP66 |

General Wiring Diagram

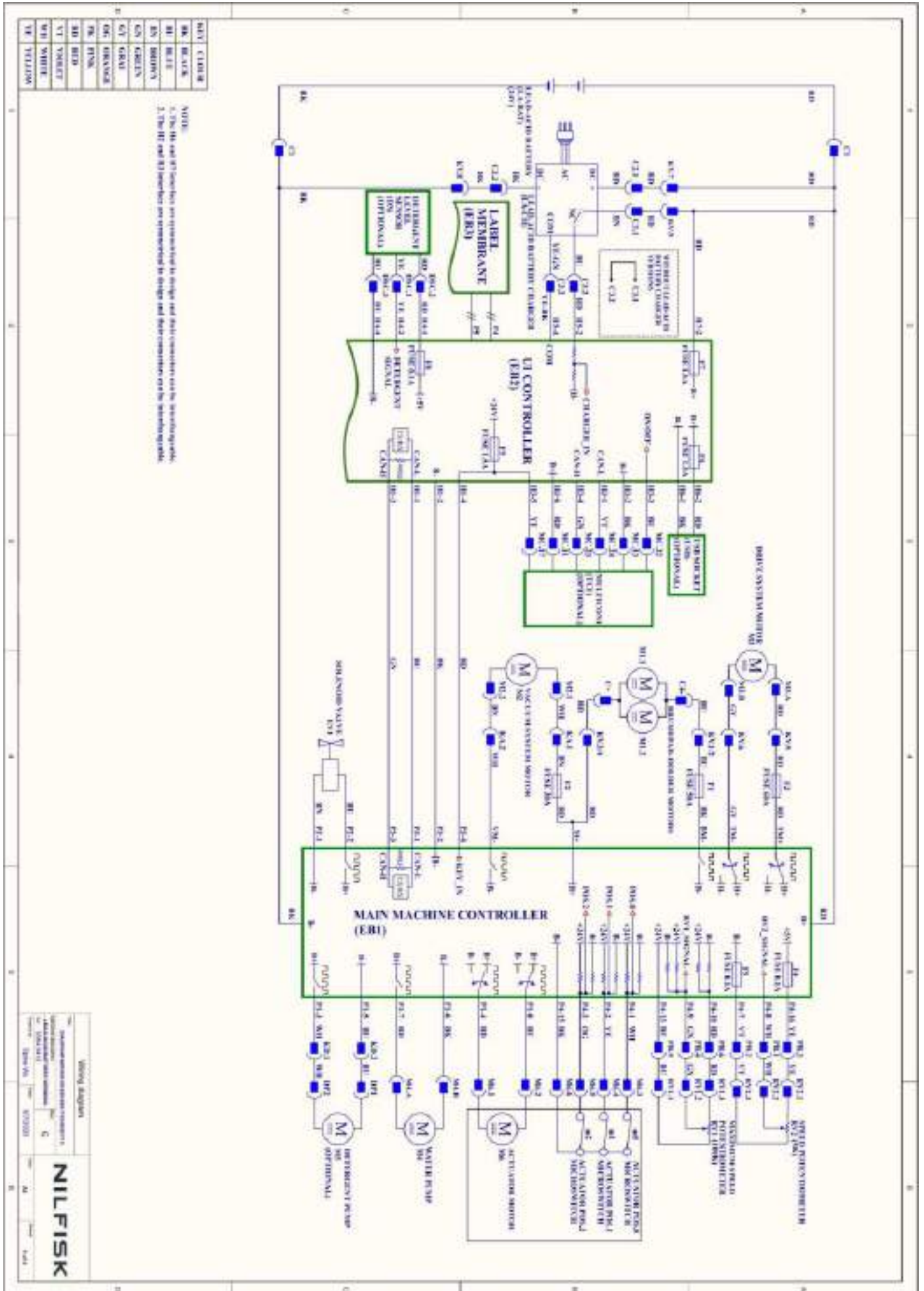

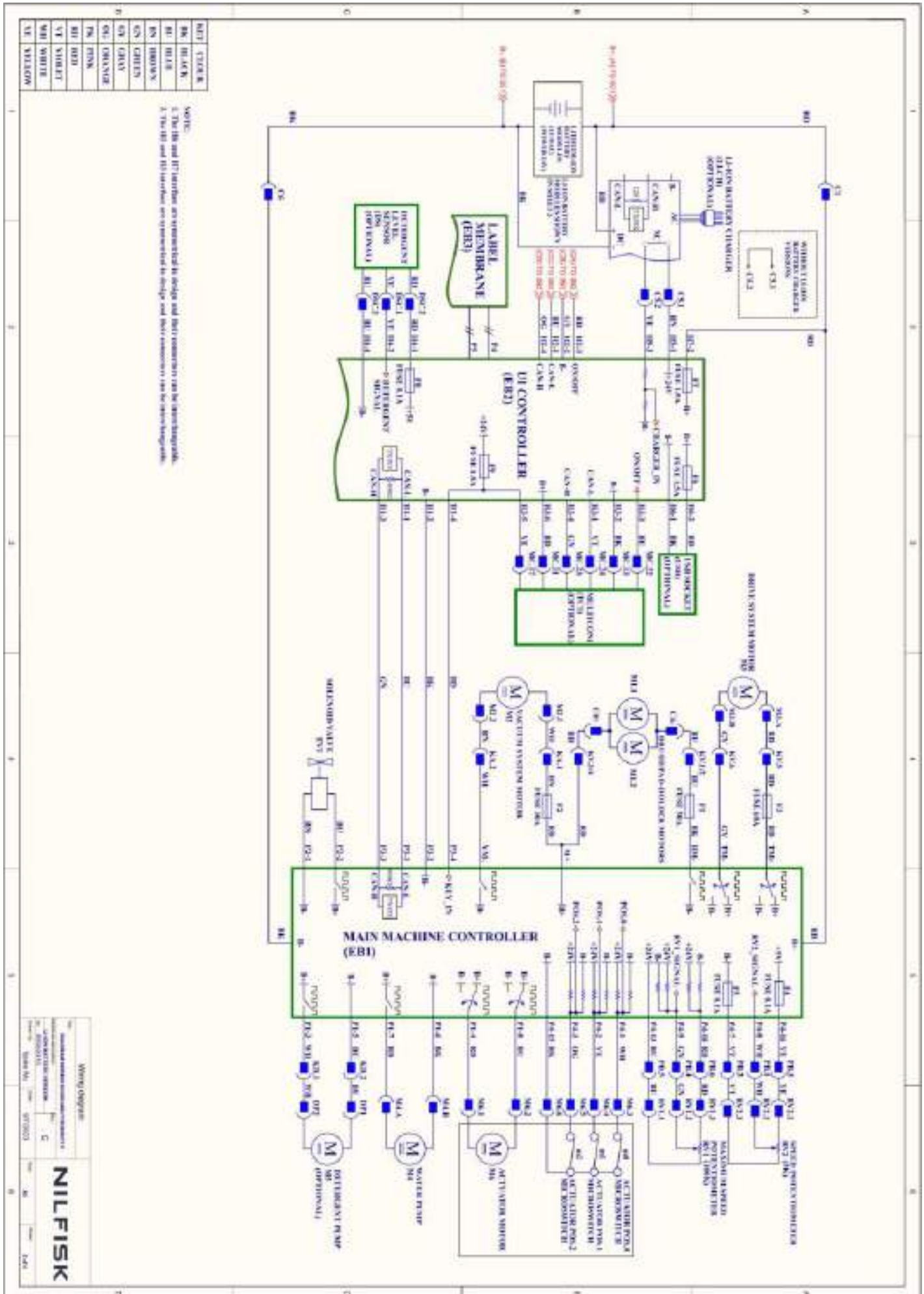

NOTE:
 1. The EB and ET labels are symmetrical in design and their positions can be interchanged.
 2. The EB and ET labels are symmetrical in design and their positions can be interchanged.

| | |
|------|-------|
| BL1 | TRUCK |
| BL2 | TRUCK |
| BL3 | TRUCK |
| BL4 | TRUCK |
| BL5 | TRUCK |
| BL6 | TRUCK |
| BL7 | TRUCK |
| BL8 | TRUCK |
| BL9 | TRUCK |
| BL10 | TRUCK |
| BL11 | TRUCK |
| BL12 | TRUCK |
| BL13 | TRUCK |
| BL14 | TRUCK |
| BL15 | TRUCK |
| BL16 | TRUCK |
| BL17 | TRUCK |
| BL18 | TRUCK |
| BL19 | TRUCK |
| BL20 | TRUCK |

Wiring Diagram

Model: SC650

Part No: 970003

Version: C

NILFISK

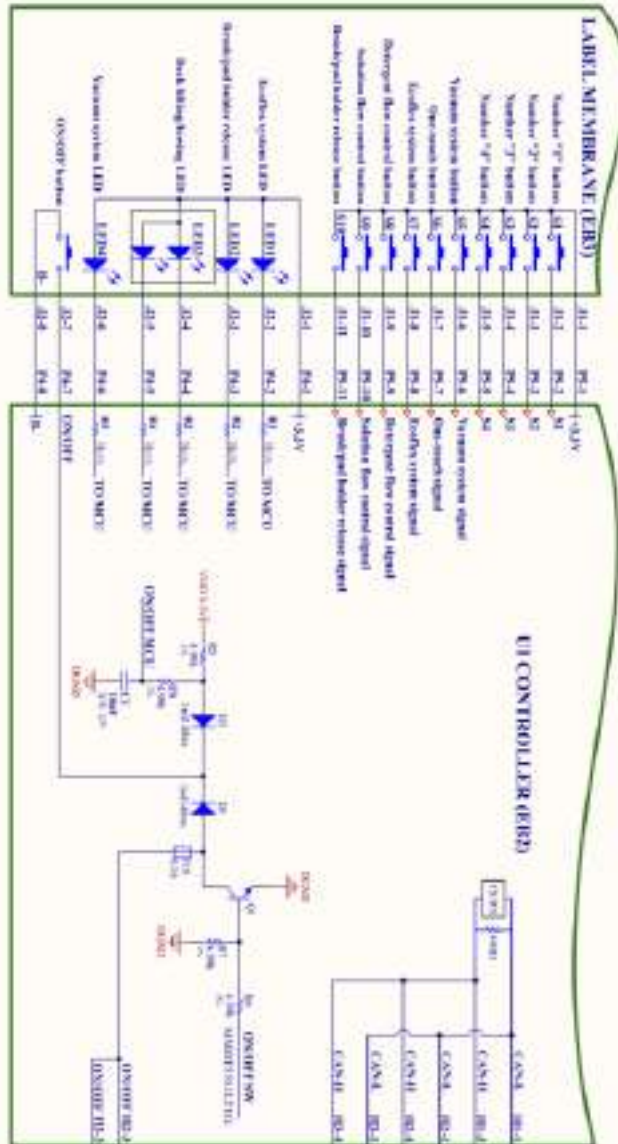

30 Solution System

Functional Description

The solution system supplies water and detergent to the brush when cleaning the floor. The solution tank is also the main machine body. There is a manual valve on the right side of the tank to close the water supply whenever maintenance must be performed on the machine. The solution flows from the tank to the tap, through the filter, water pump (M4) and solenoid valve (EV1) and then to the brush deck.

The detergent pump (M5) and detergent level sensor are presented only in EcoFlex systems. The detergent pump used in this machine is a kind of peristaltic pump, and its working voltage is from 8V to 24V. As the solution flow increases, the working voltage of detergent pump will increase, and the detergent flow will increase accordingly. The detergent pump controls the flow of detergent from the EcoFlex tank which is then transported to the flow in the main tube just before the solution enters the brush deck. The flow of detergent will pass the detergent level sensor before arriving the detergent pump. When the detergent passes the detergent level sensor, the detergent tank symbol will constantly display on the screen. When the detergent tank symbol flashes on the screen, it indicates the need to refill the EcoFlex detergent tank. In the meanwhile, the buzzer will beep for 30 seconds and stop beeping after 30 seconds.

The EcoFlex system can be selected with the specific button on the User interface (EB3).

The quantity of detergent is defined by the operator via the buttons on the User interface (EB3).

Solution flow levels 1, 2 and 3 regulate the flow of detergent solution on the basis of the machine speed so as to keep the quantity of solution dispensed per square metre of floor treated constant (for further details and modifications, see the corresponding section in the chapter Control System).

Located centrally, below the tank, there is also a hole for draining any liquid in the battery compartment.

The solution flow is regulated by water pump(M4) voltage, according to:

- Water flow rate regulation (0 - 4)
- The speed of drive motor

The solenoid valve and detergent pump and water pump operate only with the following inputs/conditions:

- Brush function on
- Forward paddle pressed
- Battery level not in condition with flashing segments.

Detergent Level Sensor

The detergent level sensor used in this machine is a kind of photoelectric sensor and its working voltage is from 3.3V to 5V. The machine uses 5V as the working voltage of detergent level sensor.

There is an infrared transmitter and a photosensitive receiver in the sensor, and the detection part is prism structure installed on the liquid flow channel between the liquid inlet pipe and the liquid outlet pipe.

When no detergent flows through the sensor, the light emitted by the transmitter will be refracted to the receiver after passing through the lens, and the high level signal will be output.

When the detergent flows through the sensor, the light is refracted into the liquid, so that the receiver can not receive or only receive a small amount of light, and the low level signal will be output.

Electrical specification (at 25°C):

| Parameter | Working voltage | Working current | Power consumption | Output voltage | Output current | Respond time |
|-----------------|-----------------|--------------------------------------|--------------------------------------|---------------------------------------|----------------|--------------|
| Value reference | 5V | 10mA (in detergent) 11mA (in air) | 50mW (in detergent) 55mW (in air) | <0.5V (in detergent) >4.6V(in air) | 1mA | 100ms |

Wiring Diagram

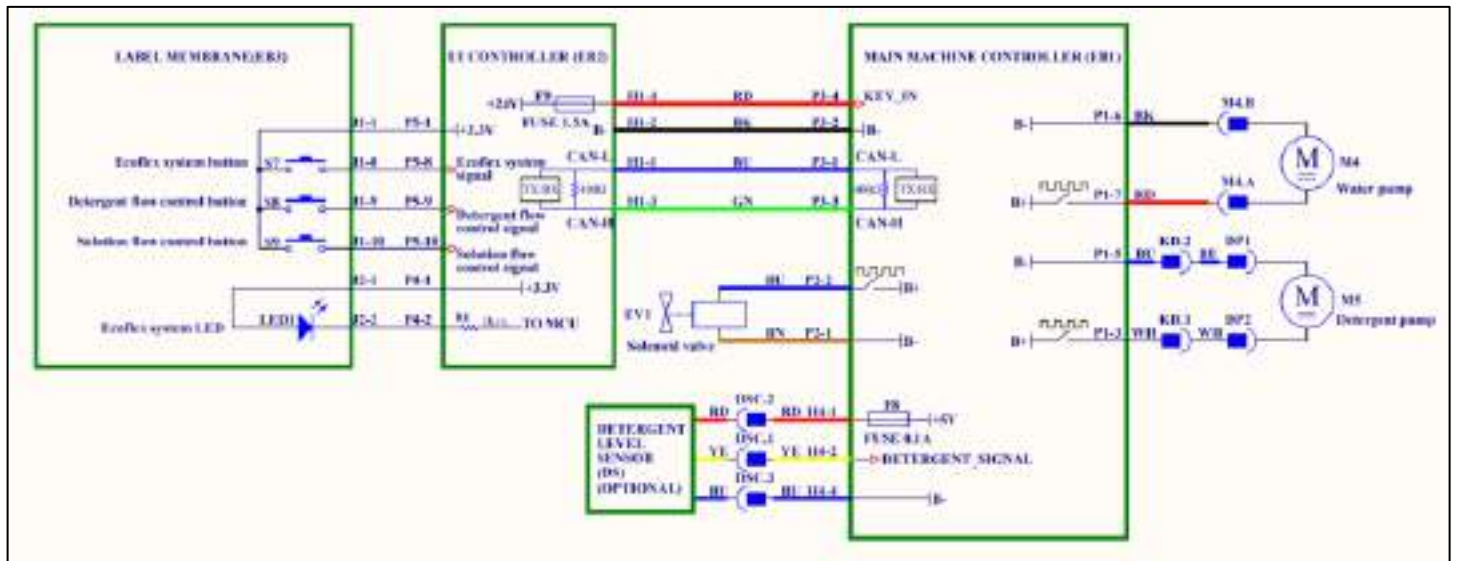

Component Locations

- Filler shut-off plug
- Solution tank
- Solution level hose
- Solution filter
- Solution tap
- Battery compartment liquid drain hole
- Solenoid valve
- EcoFlex detergent tank
- Detergent pump
- Detergent level sensor

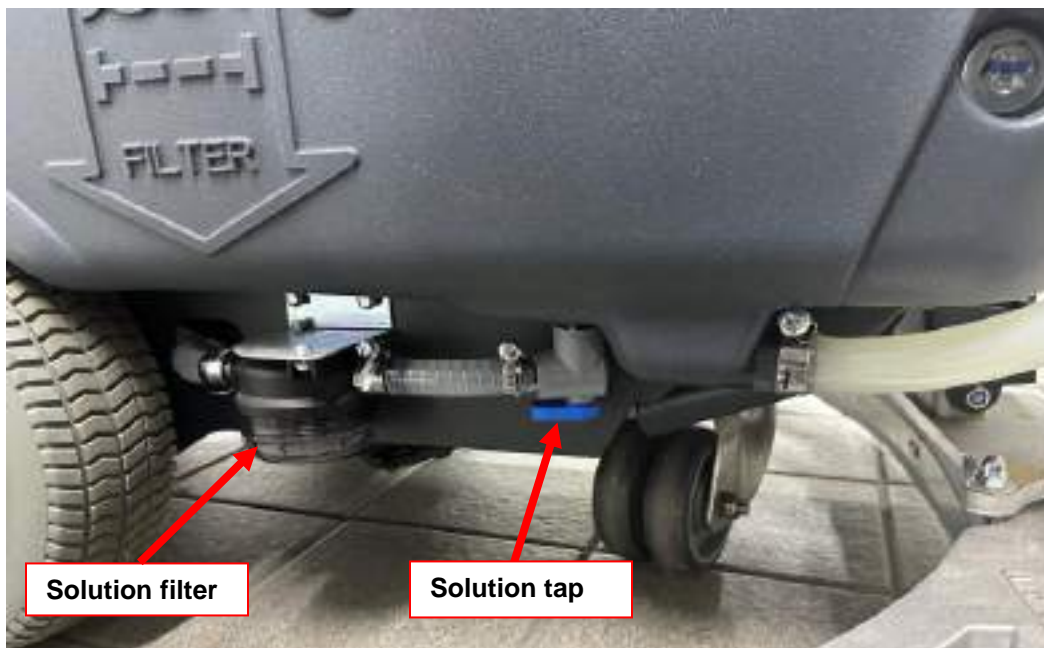

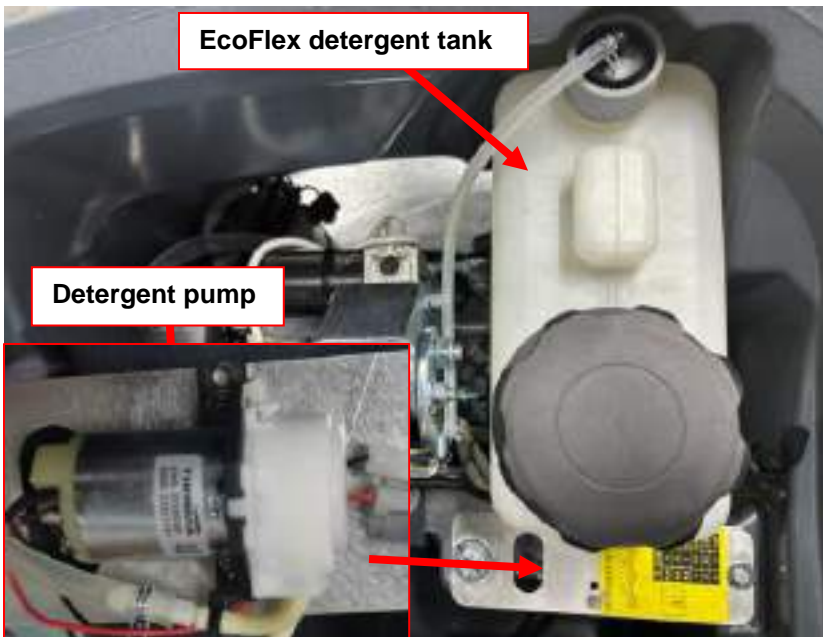

Maintenance and Adjustment

Solution Filter Cleaning

1. Drive the machine on a level floor.
2. Turn off the machine by pressing and holding the switch  for nearly a second.
3. Close the solution tap (A) under the machine, behind the left castor.
4. The tap (A) is closed when it is in the position (B) and it is open when it is in the position (C).
5. Remove the transparent cover (D) and the gasket (E), then remove the filter strainer (F). Clean and install them on the support (G).



NOTE: Install the gasket (E) and the filter strainer (F) properly on the cover (D) and on the support (G).

6. Open the tap (A) by turning it to position (C).

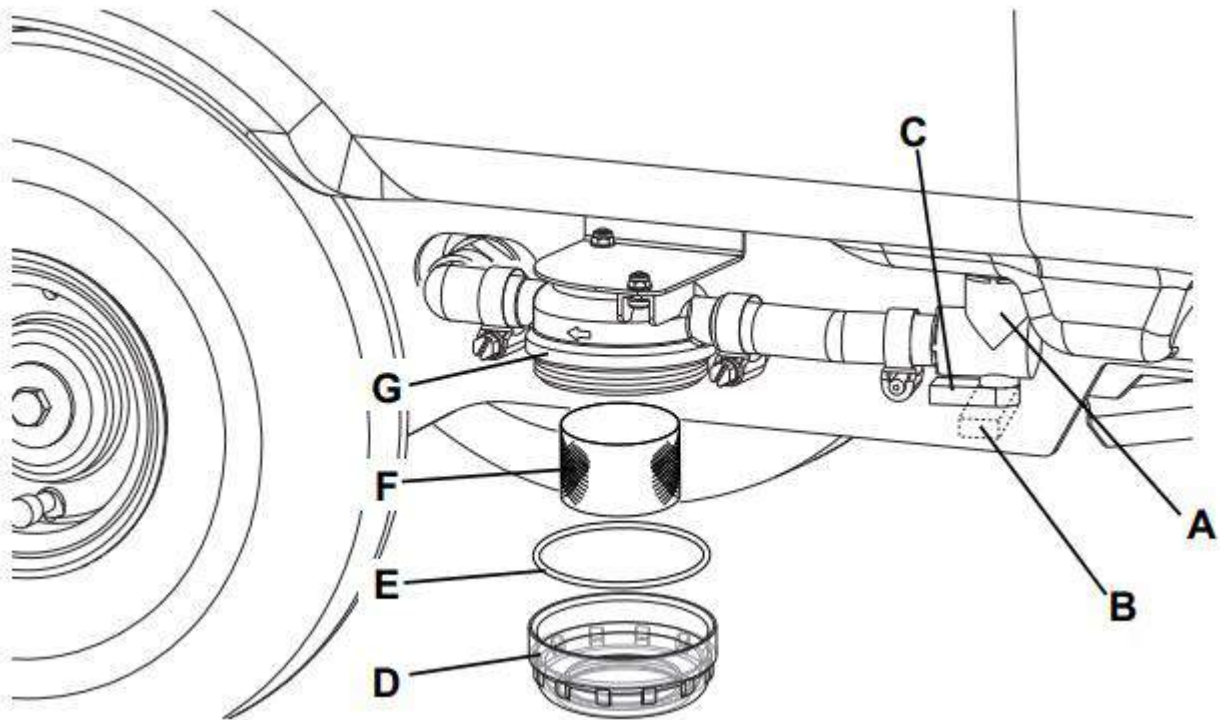

Detergent Tank Cleaning

(For machine with EcoFlex™ system)

Clean the detergent tank according to the following procedure:

For standard version detergent tank

1. Drive the machine to the appointed disposal area.
2. Switch off the machine and disconnect the battery connector.
3. Lift the recovery tank.
4. Unscrew the union and disconnect the hose from the detergent tank.
5. Remove the detergent tank.
6. Unscrew the plug (A) and wash the detergent tank (B) in the appointed detergent disposal area.
If necessary, remove the supply hose (C) and clean it, especially in area of the vacuum end pipe (D). Install the supply hose (C)
7. Check that the plug vent hole (E) is not clogged, by driving in air and checking if it comes out from the outer hole (F). If necessary, clean the hole with compressed air. Install the plug (A)
8. Install the detergent tank and connect the hose.
9. When the detergent tank and the supply hose have been drained, the EcoFlex™ system must be drained too by running the system with clean water only (see the procedure in the following paragraph).

For bottle style version detergent tank:

10. Follow the step 1–4, unscrew the cap (G) from the tank (H).
11. Remove the tank (H)
12. Wash the detergent tank (H) in the appointed detergent disposal area.
13. Install the tank (H) and connect the hose.

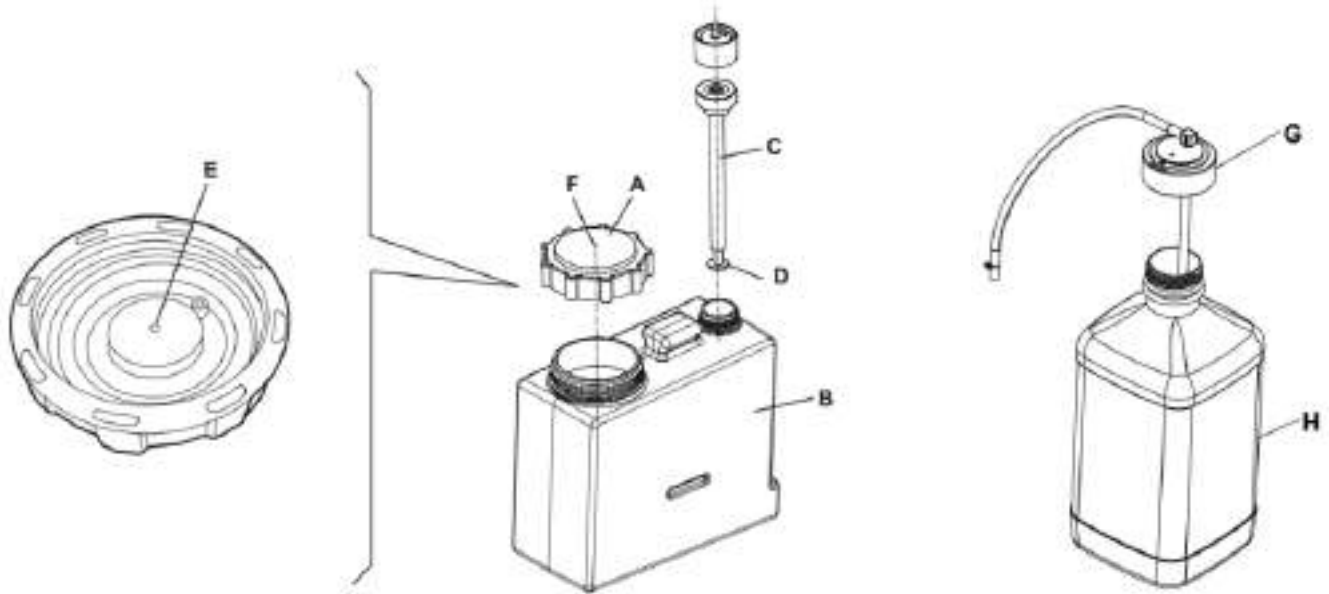

Standard version









Bottle style version

EcoFlex™ System Draining

(For machine with EcoFlex™ system)

Clean the detergent tank as shown in the previous section.

To remove residual detergent from the detergent hoses and pump, proceed as follows.

1. Press the switch  to start the machine.
2. Press the switch . Check that the detergent quantity indicator  on the display has at least one segment lit.
3. Press and hold switches  and  at the same time until screen  appears on the display (after approximately 5 seconds).
4. Release switches  and  and wait for the countdown timer on the display to finish and the vacuum system to be activated.
5. Collect the detergent remained on the floor.
6. Pressing and hold the switch  for nearly a second to turn off the machine.
7. Raise the recovery tank, then check that the detergent tank hose is empty; if not, perform steps 3 to 7 again.



NOTE:

The draining cycle lasts about 30 seconds, then the vacuum function automatically turns on, which allows to remove the detergent remained.

The draining cycle can also be performed with the detergent tank full of water, thus cleaning the system thoroughly. It is advisable to perform this type of draining to clean the system from dirt and deposits if the machine has not been used/cleaned for a long time.

The draining cycle can be performed also to quickly fill the detergent supply hose when the detergent tank is full, but the system is still empty.

If necessary, the draining cycle can be repeatedly performed.

Troubleshooting

| Trouble | Possible Causes | Remedy |
|--|---|--|
| Small amount of solution or no solution reaches the brush | If the machine is first used, it needs some time to wait for the water fill with the tube | Wait for 2-3 minutes and check if the solution reaches the brush |
| | The solution filter is clogged/dirty | Clean the filter |
| | Solution supply valve locked in (semi) closed position | Replace the valve |
| | The inlet tube to the inlet of water pump is not locked | Lock it down |
| | Solenoid valve (EV1) broken or electrical connection interrupted | Replace the solenoid valve/repair the electrical connection |
| | The water pump (M4) is broken or there is an open in the electrical connection | Replace the pump/repair the electrical connection |
| | Presence of debris in solution tank blocking the outlet hole | Clean the tank |
| | Presence of debris in the solution hose, blocking the passage of the liquid | Clean the hoses |
| | Main machine controller (EB1) faulty | Replace |
| | UI controller (EB2) faulty | Replace |
| | Label membrane (EB3) faulty | Replace |
| The solution leaks on the brushes or floor when the machine is off | Presence of dirt or scale in solenoid valve (EV1) | Clean the solenoid valve |
| | Solenoid valve (EV1) broken | Replace the solenoid valve |
| The EcoFlex system detergent is not reaching the brush, or is not arriving in sufficient quantity On the brush comes only water | The detergent flow percentage is too low | Check/change the percentage |
| | The hydraulic circuit upstream of the detergent pump is not triggered | Check if the hose is filled and, if necessary, perform one or more draining cycles |
| | The detergent pump (M5) is broken or there is an open in the electrical connection | Replace the pump/repair the electrical connection |
| | The head of the detergent pump (M5, peristaltic pump) is exhausted | Replace the head of the detergent pump |
| | The motor of the detergent pump (M5, peristaltic pump) is broken | Replace the detergent pump |
| | There is foreign material/debris in the detergent tank clogging the output hole | Clean the tank |
| | There is debris in the detergent hoses clogging the detergent flow | Clean the hoses |
| | The detergent flow regulation button  is not working correctly | Replace the Label membrane (EB3) |
| | Main machine controller (EB1) faulty | Replace |
| | UI controller (EB2) faulty | Replace |
| | Label membrane (EB3) faulty | Replace |

| Trouble | Possible Causes | Remedy |
|--|--|--|
| The EcoFlex system will not activate | Label membrane (EB3) faulty | Replace |
| The detergent tank symbol flashes on the screen when EcoFlex detergent tank is full | Detergent does not pass the detergent level sensor | Let the detergent pump work for several minutes and check if the phenomenon still exists. If yes, replace the sensor |
| | Detergent level sensor is broken | Replace |
| The detergent tank symbol constantly displays on the screen when EcoFlex detergent tank is empty | Detergent remains in the detergent level sensor | Clean the Detergent level sensor |
| | Detergent level sensor is broken | Replace |

Removal and Installation

Water Pump

Removal

1. Drive the machine to the appointed disposal area.
2. Switch off the machine and disconnect the battery connector.
3. Lift the recovery tank.
4. Cut the cable tie (F), disconnect the connector (A).
5. Loosen the clamps (B) and disconnect the hoses (C) from the water pump (D).
6. Remove the screws (E).
7. Remove the water pump (D).

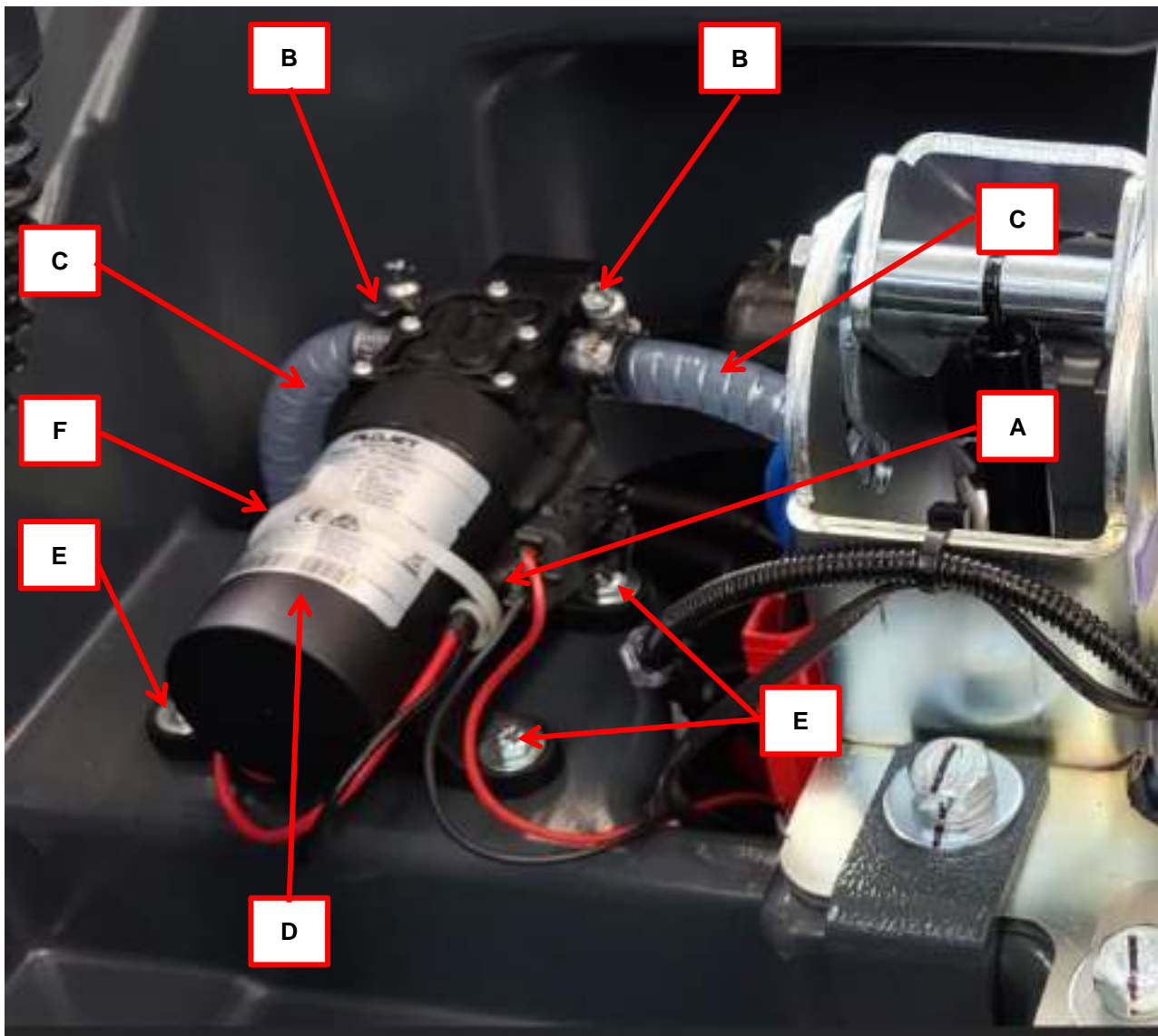

Installation

8. Assemble the components in the reverse order of disassembly.



Solenoid Valve (EV1)

Removal

1. Drive the machine on a level floor or on a hoisting system to facilitate the disassembly procedures.
2. Press the power switch on the machine . After the logo "NILFISK" disappears on the screen, Input the password by push the "1234" button to reach the menu.
3. Lower the brush deck by pressing the One-Touch button .
4. Switch off the machine and disconnect the battery connector.
5. Unscrew the two screws (A).
6. Disconnect the fitting (B) and fitting (C) from the solenoid valve(D).
7. Unscrew the screw (E).
8. Disconnect the connection (F), then remove the solenoid valve (D).

Installation

9. Assemble the components in the reverse order of disassembly.

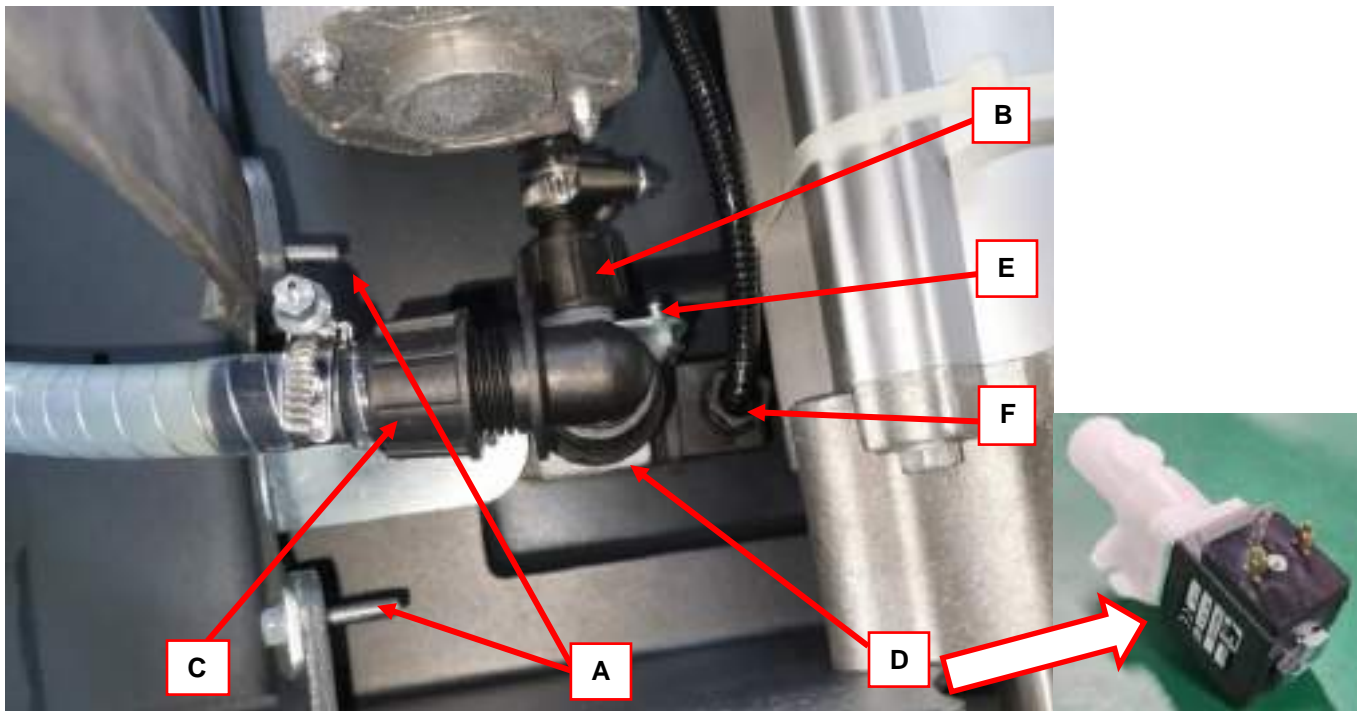

Detergent Pump

Removal

1. Drive the machine on a level floor or on a hoisting system to facilitate the disassembly procedure.
2. Switch off the machine and disconnect the battery connector.
3. Lift the recovery tank.
4. Unscrew the two screws (A) and turn over the plate (B)..
5. For remove only the head of the detergent pump:
 - a. Disconnect the tank hose (C) and brush hose (D).
 - b. Remove the head of the detergent pump (E) to the detergent pump motor .
6. For remove the detergent pump:
 - a. Disconnect the connectors (F) and the tank hose (C) and brush hose (D).
 - b. Unscrew the two screws (G) and remove the detergent pump (H).

Installation

Assemble the components in the reverse order of disassembly, ensuring the supply hoses (C) and (D) are correctly fitted on the detergent pump.

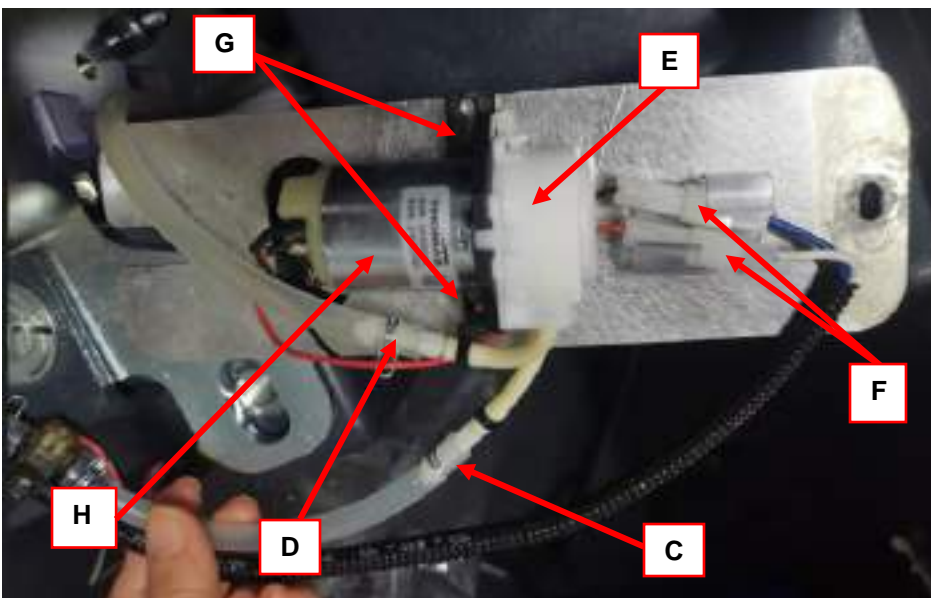
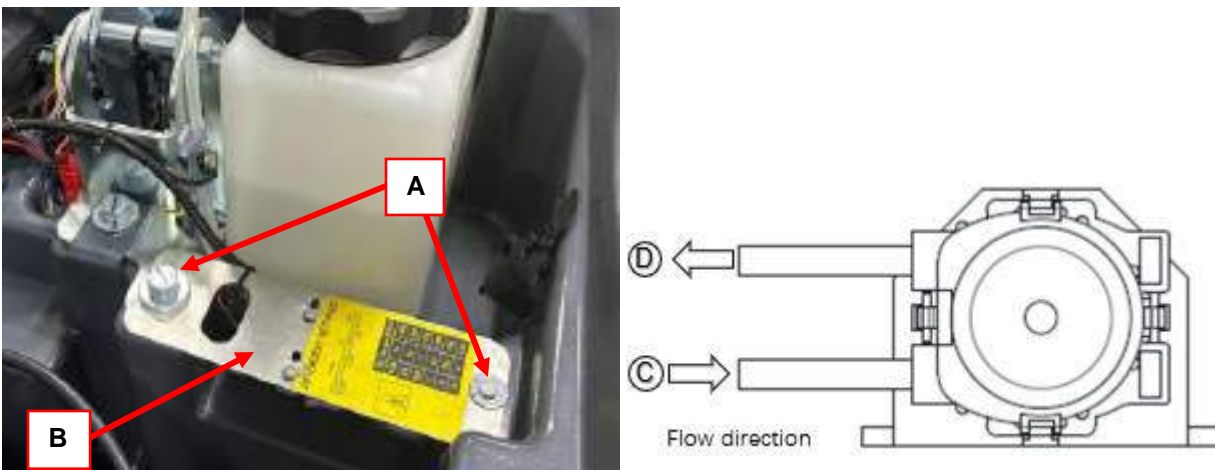

Specifications

| Description | SC650 66D | SC650 71D | SC650 85D | SC650 71C |
|--------------------------------------|---|----------------------------------|----------------------------------|----------------------------------|
| Solution tank capacity | 80 L | | | |
| Solution flow (max) per setting | 1,27/ 2,55/ 5,1 cl/m 3,8l/min | 1,37/ 2,75/ 5,5 cl/m 3,8l/min | 1,62/ 3,25/ 6,5 cl/m 3,8l/min | 1,37/ 2,75/ 5,5 cl/m 3,8l/min |
| EcoFlex system detergent flow | 0.25% ÷ 3% | | | |
| EcoFlex kit tank capacity | 5 L for standard version, 2.5L for bottle style version | | | |
| Solenoid valve coil resistance @25°C | ≈55Ω | | | |

34 Scrub System

Functional Description

The disc brush system can be started by the operator.

The two disc brushes must rotate opposite each other. At the operator's position, looking from the top of the machine, the right side must be rotated counterclockwise and the left side clockwise.

The rotating brush system cleans the surface of the floor. The main component of the brush system is the deck where the brush or the pad holder with pad suitable for the type of surface to be cleaned is installed. The brush deck is installed on a frame to which the electrical actuator and the four levers for connection to the frame integrated with the brush motor is coupled.

The electrical actuator (M6), with limit microswitches, lifts and lowers the deck. The operating and washing pressure depend on the weight of the deck. The disc brush system permits the extra pressure function. Extra pressure is selected via the one-touch button or ecoflex system switch on the Label membrane (EB3). And the cylindrical brush system does not have extra pressure function.

Brush rotation occurs only when the brush motors (M1) are driven by the Main machine controller (EB1) following activation of the paddle.

The brush system uses the mixed solution of water and detergent to wash the floor.

In case of brush motor overload, a safety system stops the brush to prevent continuous overload.

If the overload takes place when the extra pressure function is on, the system automatically turns the extra pressure function off. If the overload persists, the brush stops.

The overload is detected by monitoring the current flow on the brush motor. If the motor current reaches the value stored in the parameter "VS1" (for disc brush) / "VS2" (for cylindrical brush) and the overload persists, the brush motor will stop following a delay which varies on the basis of the extent of the overload.

To start scrubbing again after a brush stop due to overload, turn the machine off. Then restart the machine.

To work properly, the brush motor (M1) needs the following:

- Brush function on
- Forward paddle pressed.
- Battery level not in critical condition with flashing segments.

Brush Release Function

To release the brush from its hub, the brush motor starts up and then stops immediately. After the brush motor starts up for several seconds, the wires on both sides of the brush motor will be connected to the positive terminal of power supply at the same time, generating reverse current to stop the motor abruptly. The brush's inertia thus causes it to disengage from the hub.

Actuator Position Microswitches

The actuator motor has three position microswitches inside. When the actuator motor is retracted, the switch m0 is open and the voltage measured in P4-1 is about 13V, while the switches m1 and m2 are closed and the voltages measured in P4-2 and P4-3 is 0V. When the actuator motor extends to the normal brush pressure level, the switch m1 is open and the voltage measured in P4-2 is about 13V, while the switches m0 and m2 are closed and the voltages measured in P4-1 and P4-3 is 0V. When the actuator motor extends to the extra-pressure level, the switch m2 is open and the voltage measured in P4-3 is about 13V, while the switches m0 and m1 are closed and the voltages measured in P4-1 and P4-2 is 0V.

Wiring Diagram

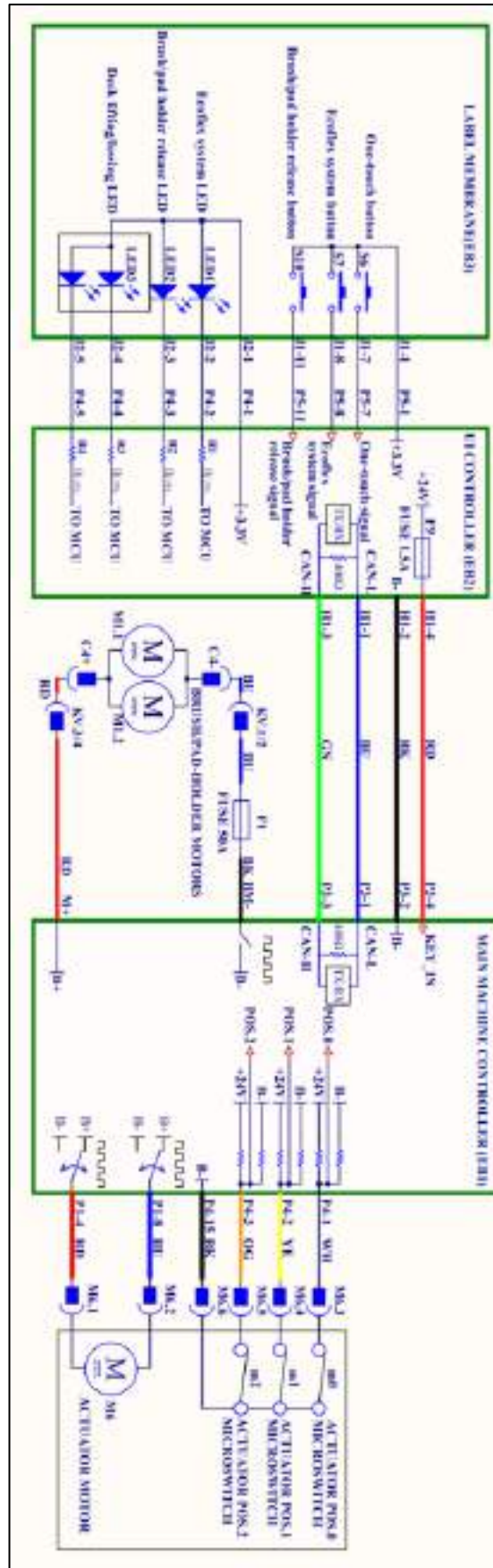

Component Locations

- Brush motors (M1)
- Brush deck
- Brush
- Drive hub
- Deck lifting levers
- Brush deck support
- Brush deck lifting/ lowering actuator
- Actuator system wiring connection
- Main machine controller (EB1)
- Brush motors fuse (F1)

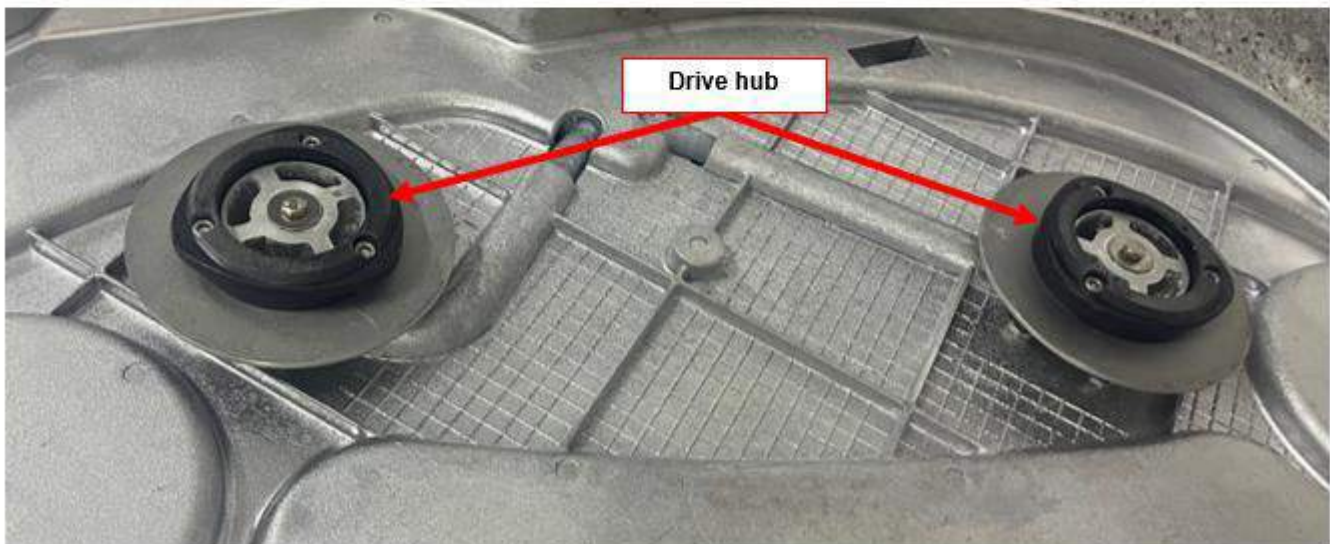
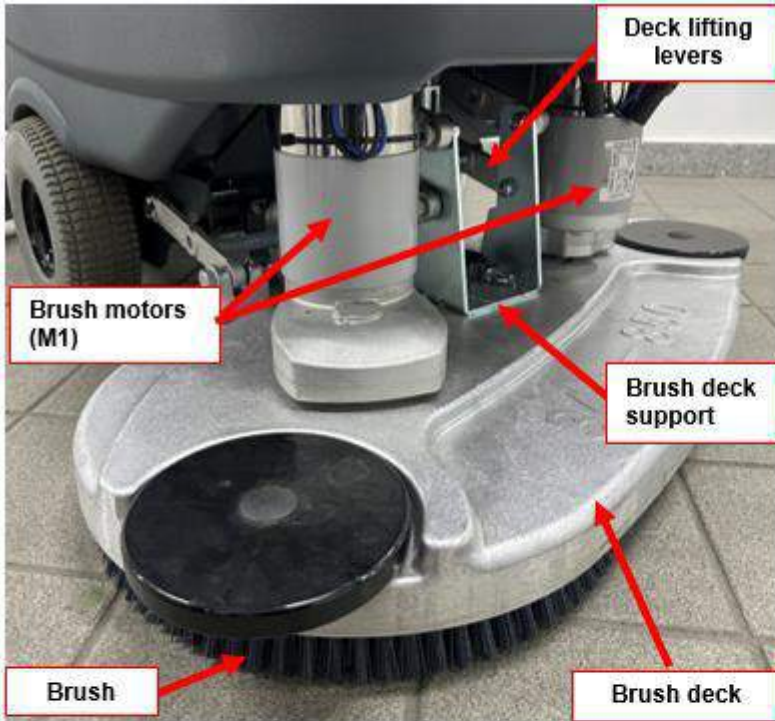

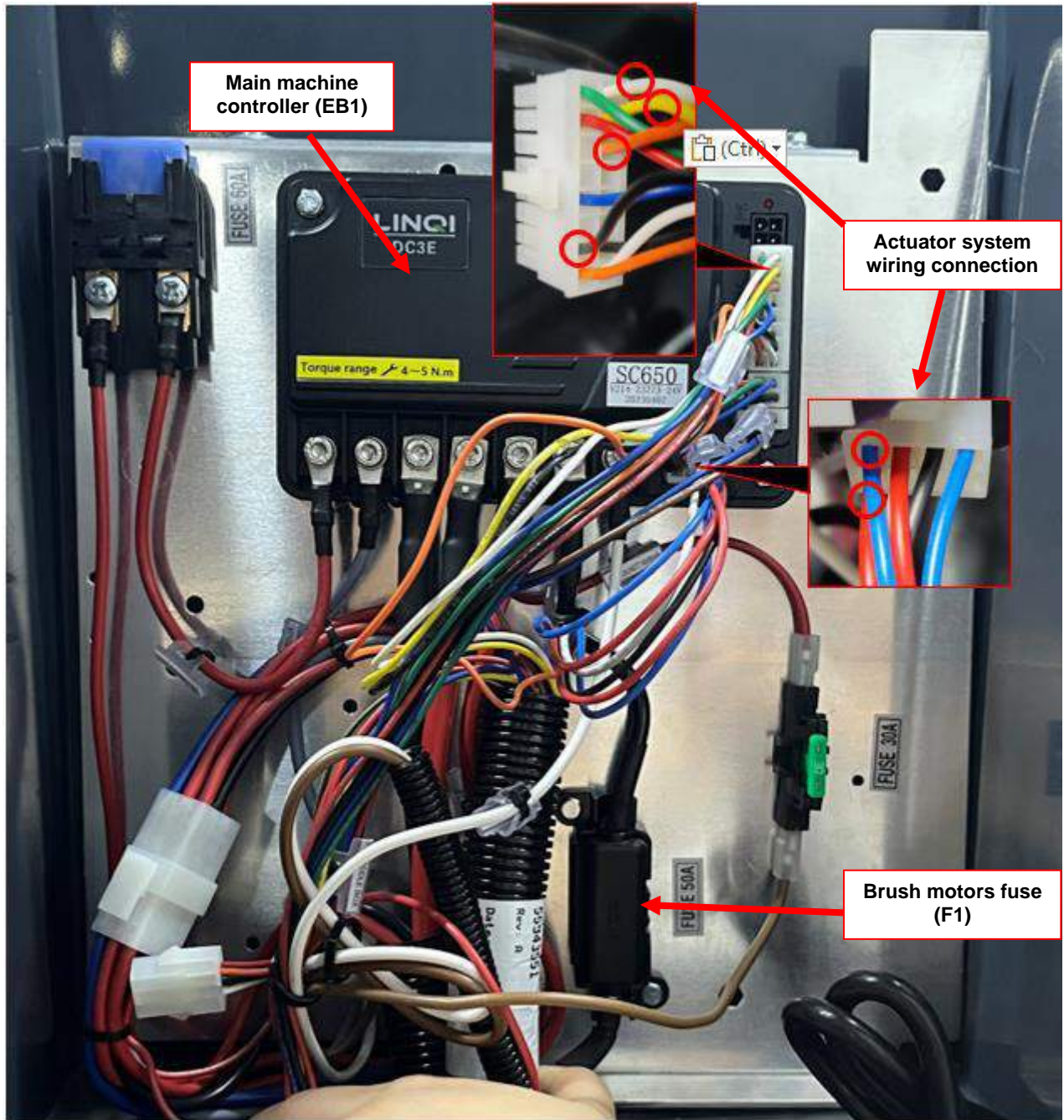



Maintenance and Adjustments

Brush Motor Amperage Check



Warning! This procedure must be performed by qualified personnel only.

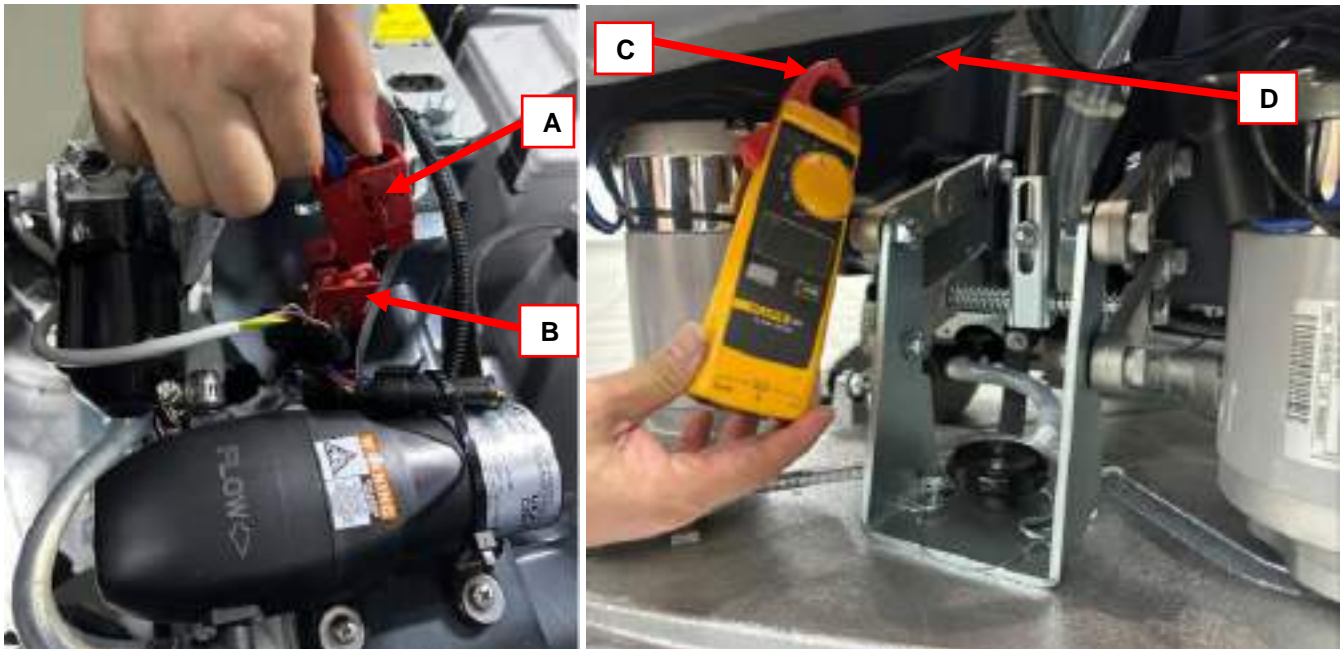

1. Drive the machine on a level floor.
2. Remove the brush.
3. Disconnect the drive system connector (A) on the Main machine (B) to disable machine movement.
4. Press the power switch on the machine . After the logo "NILFISK" disappears on the screen, input the password by push the "1234" button to reach the menu.
5. Press the One-Touch button  to lower the brush deck.
6. Apply the amperometric clamp (C) to the electrical wire (D) of the brush motor. Note that apply to one brush motor wire only.
7. Activate the brush by pressing the paddle, then check that the brush motor current draw is between 3 and 4A at 20V (*).
8. Deactivate the brush by releasing the paddle and raise the brush deck by pressing the One-Touch button .
9. Remove the Amp clamp (C).
10. If the amperage is higher, perform the following procedures to detect and correct the abnormal amperage:
 - Remove any debris wrapped around the motor shaft which may be resisting its rotation.
 - If amperage is still higher than normal, replace the motor.



(*) Voltage value supplied by the Main machine controller to the brush motor when the motor current draw is less than the value of the RPM parameter.

Check/Replacement/Adjustment of Driving Belts Between Motors and Cylindrical Brushes (For SC650 71C)

Check

1. Drive the machine on a level floor.
2. Press the power switch on the machine . After the logo "NILFISK" disappears on the screen, input the password by push the "1234" button to reach the menu.
3. Lower the brush/pad-holder deck by pressing the switch .
4. Turn off the machine by pressing and holding the switch  for nearly a second.
5. Remove the screws (A) and remove the covers (B).
6. Visually inspect the driving belt (C) for integrity, cuts, tears or cracks and, if necessary, replace it according to the following procedure.
7. Check the driving belt tension (C) according to the following procedure.

Replacement

8. If the belt (G) is to be replaced, loosen the nut (D) and move the pulley (E) to loosen the belt.
9. Remove or replace the driving belt.
10. Stretch the driving belt (according to the following procedure).

Belt tensioning

11. Check the tension of the driving belt (C) between motor and brush. The tension is correct:
 - When pressing the driving belt in its centre with a force of 22 lbs (10 kg) (F), the driving belt bends for 0.20 in (5 mm).
 If necessary, stretch the driving belt according to the following procedure:
12. Loosen the nut (D) and adjust the position of the pulley (E). When tensioning procedure has been performed, tighten the nut (D).
13. Repeat step 11.

Reset

14. Perform steps 3, 4 and 5 in the reverse order.

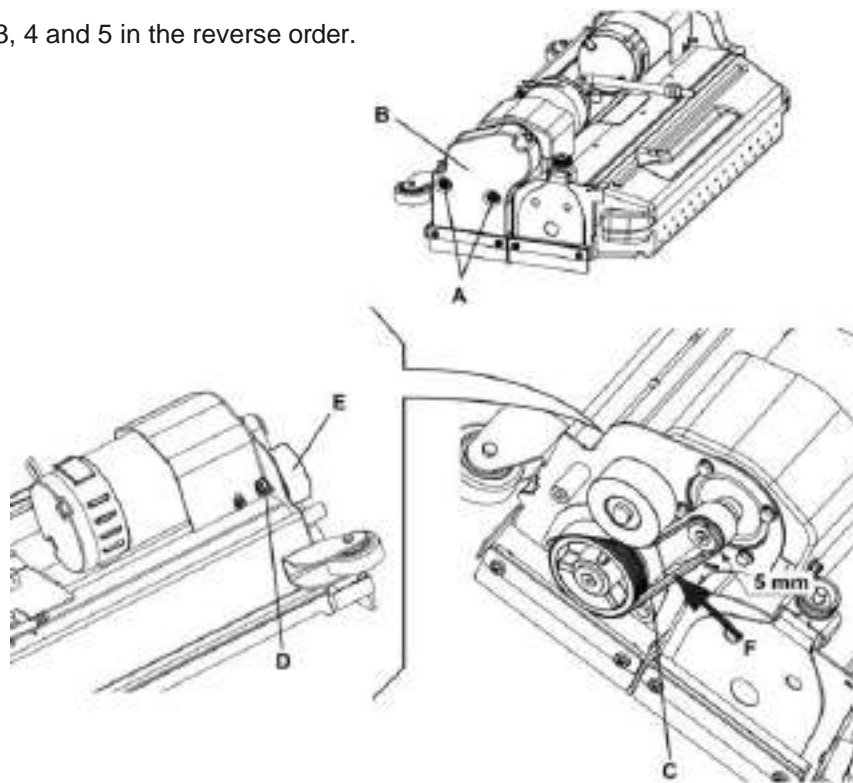



Troubleshooting

| Trouble | Possible Causes | Remedy |
|--|---|------------------------------|
| All brushes do not turn | The wiring harness between Main machine controller (EB1) and brush motor is damaged | Repair |
| | The brush motor connector is disconnected | Connect |
| | The brush motor fuse is open | Replace |
| | The Main machine controller (EB1) is damaged | Replace |
| One brush does not rotate (For models with two brushes) | The motor carbon brushes are worn | Replace |
| | Bulky debris or cords around the brushes or between the brushes and its flange | Remove and clean the brushes |
| | The motor is faulty | Repair or replace |
| | The wiring harness is damaged | Repair |
| The brushes cannot be lifted/lowered or the extra pressure function cannot be turned on (See also the Electrical System chapter, Main machine controller (EB1) diagnosis) | The deck lifting/lowering actuator is broken | Replace |
| | There is an open in the actuator wiring harness | Check the connections |
| | The Main machine controller (EB1) is damaged | Replace |

Removal and Installation

Brush for SC650 66D/ 71D/ 85D



Installation

1. According to the kind of cleaning to be performed, the machine can be equipped either with the brush (A) or the pad-holder (B) with pad (C) together with the appropriate deck.
2. Press the power switch on the machine . After the logo "NILFISK" disappears on the screen, input the password by push the "1234" button to reach the menu.
3. Bring the machine speed to minimum by turning the knob to the far left.
4. With the brush deck raised, position the brush (A) or pad-holder (B) under the deck.
5. Press the One-Touch button  to lower the deck onto the brush.
6. To engage the brush, press the paddle, then release it. If necessary, repeat the procedure until the brush is engaged.



CAUTION! Turn the machine speed to idle and slightly press the paddle, otherwise the machine starts to move.

Removal

7. To remove the brush, the deck must be lifted by pressing the One-Touch button , then press the brush release button . When the display shows the  icon, wait until the brush is lowered onto the floor.

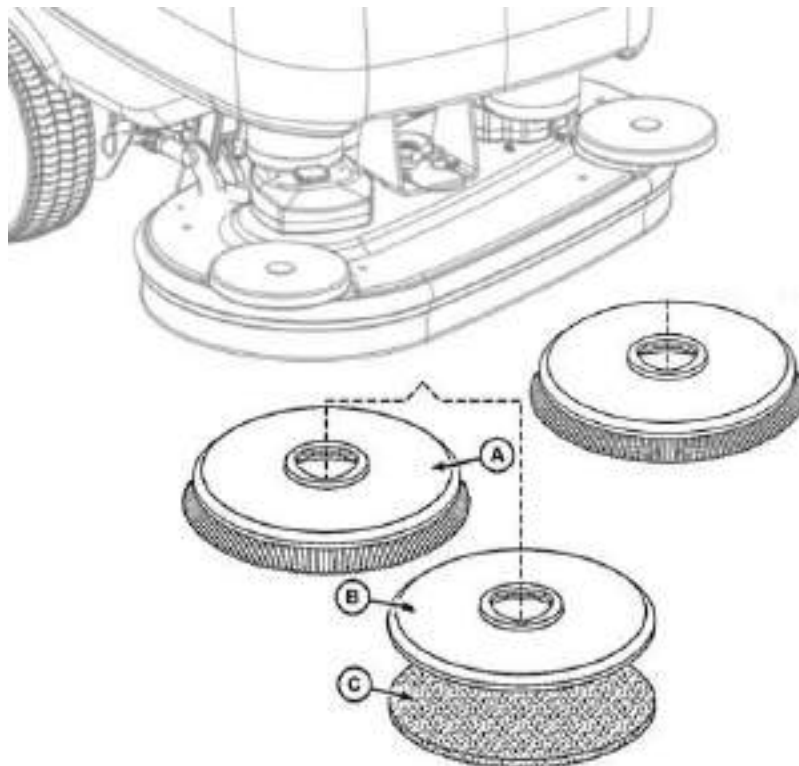

Brush for SC650 71C

Installation

1. According to the kind of cleaning to be performed, the machine can be equipped with the brush.
2. Press the power switch on the machine  , After the logo “NILFISK” disappears on the screen, Input the password by push the “1234” button to reach the menu.
3. Bring the machine speed to minimum by turning the knob to the far left.

Removal

4. To remove the brush, the deck must be lifted by pressing the One-Touch button  . Then remove the debris container (A) by pulling it on one side with the handle (B). Empty and wash the debris container (A), and then install it by engaging it on the inside fasteners.



CAUTION! Turn the machine speed to idle and slightly press the paddle, otherwise the machine starts to move.

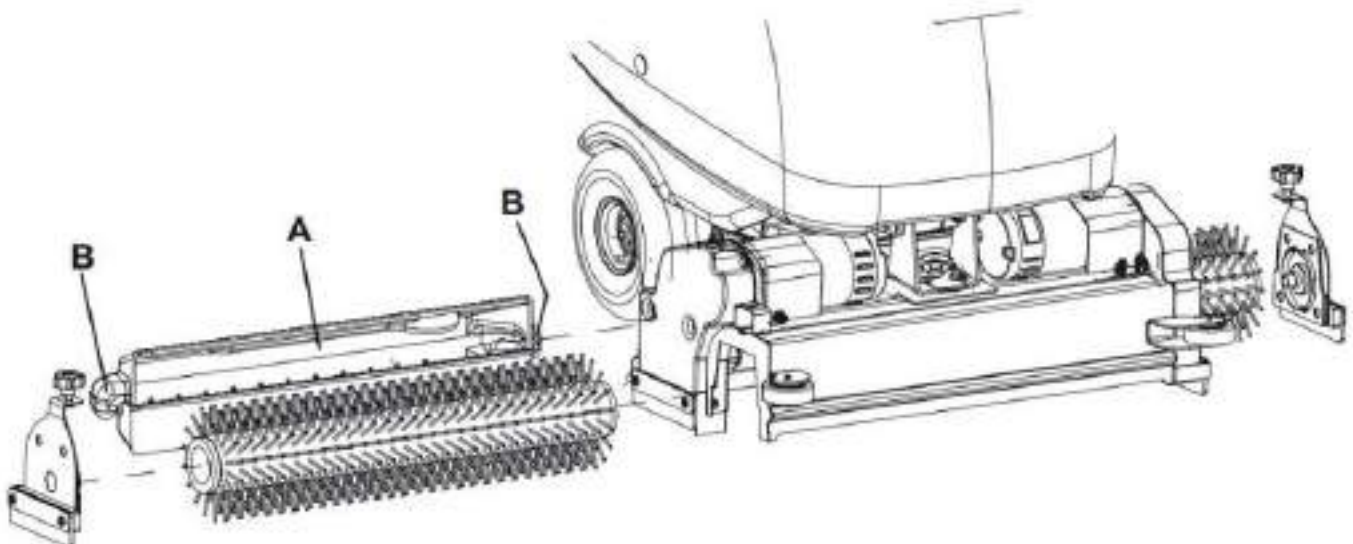

Brush Deck

Removal

1. Drive the machine on a level floor or on a hoisting system to facilitate the disassembly procedures.
2. Remove the brushes/pad-holders according to the procedure shown in the relevant paragraph. Do not remove the cylindrical brushes.

3. Press the power switch on the machine . After the logo "NILFISK" disappears on the screen, input the password by push the "1234" button to reach the menu.

4. Lower the brush/pad-holder deck by pressing the One-Touch button .
5. Switch off the machine and disconnect the battery connector.
6. Remove the safety pins (A) and [for brush/pad-holder deck only] the mounting pin (B).
7. Disconnect the red connector (C).
8. Disconnect the solution hose union (D).
9. Unscrew the mounting handwheel (E), then remove the brush/pad-holder deck (F).

Installation

10. Assemble the components in the reverse order of disassembly, and note the following:
 - When the brush/pad-holder deck is installed, fasten the lever with the pin (B).

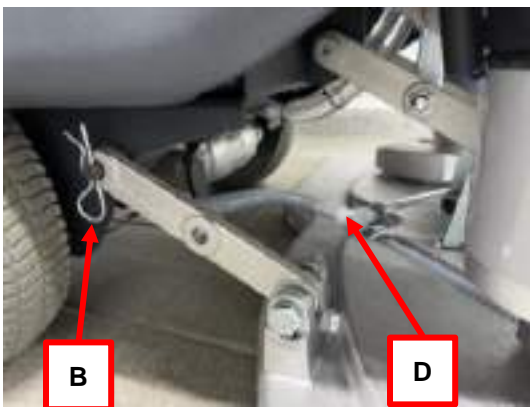

Brush Motor for SC650 66D/ 71D/ 85D

Removal

1. Remove the brush/pad-holder deck (see the procedure in the relevant paragraph).
2. At the workbench, remove the screw (A) from the reduction unit which has to be disassembled.
3. Remove the hub assembly (B) with a puller.
4. Remove the screws (C).
5. Remove the reduction unit (D).
6. Recover the key (E).

Installation

7. Assemble in the reverse order of disassembly.



NOTE

For further information on deck components see the Spare Parts List.



NOTE

Figure showing SC650 85D deck.

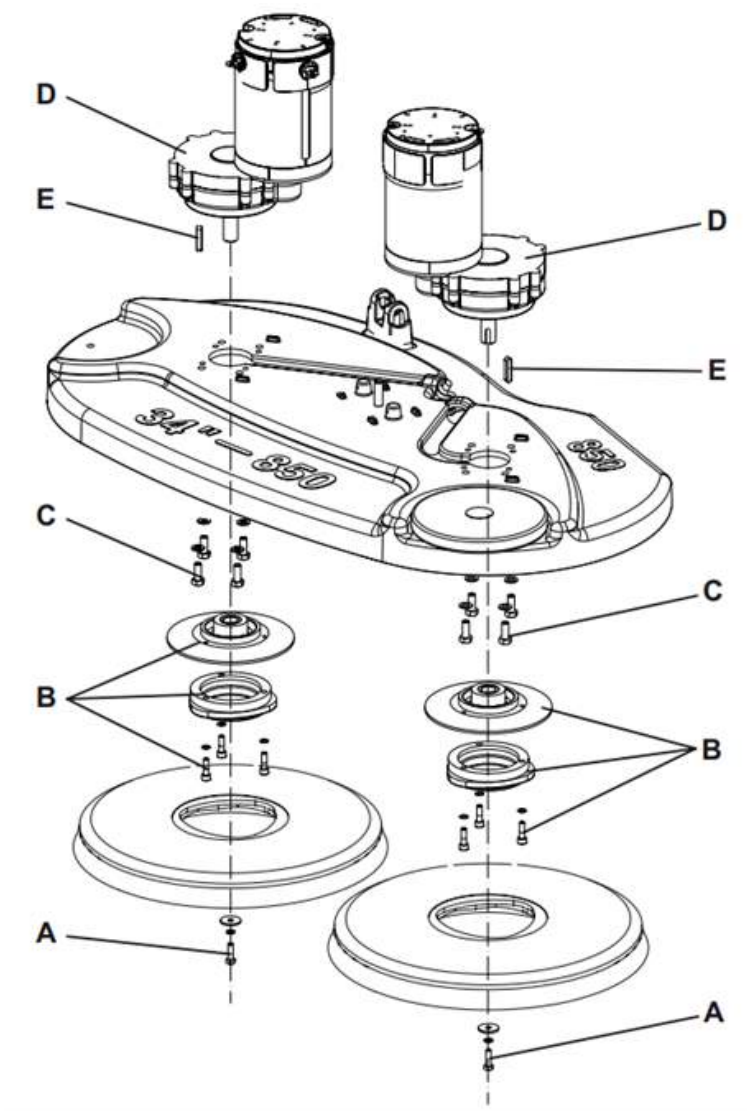

Remove the hub assembly with a puller.



Brush Motor for SC650 71C

Removal

1. Remove the cylindrical brush deck (see the procedure in the relevant paragraph).
2. At the workbench, remove the screw (A) from the motor which has to be disassembled.
3. Remove the case (B).
4. Loosen the nuts (C) and remove the protection (D).
5. Loosen the nut (E) and move the pulley (F) to loosen the belt (G).
6. Remove the belt (G).
7. Remove the screws (H).
8. Remove the motor (I).

Assembly

9. Assemble the components in the reverse order of disassembly, and note the following:
 - The electrical connections (J) of the motor (I) must be turned upwards.
 - The connection (L) of the carbon brush protection clamps (K) must be positioned as shown in the figure.
 - Install the belt (G) and tension it properly (see the procedure in the relevant paragraph).



NOTE

For further information on deck components see the Spare Parts List.

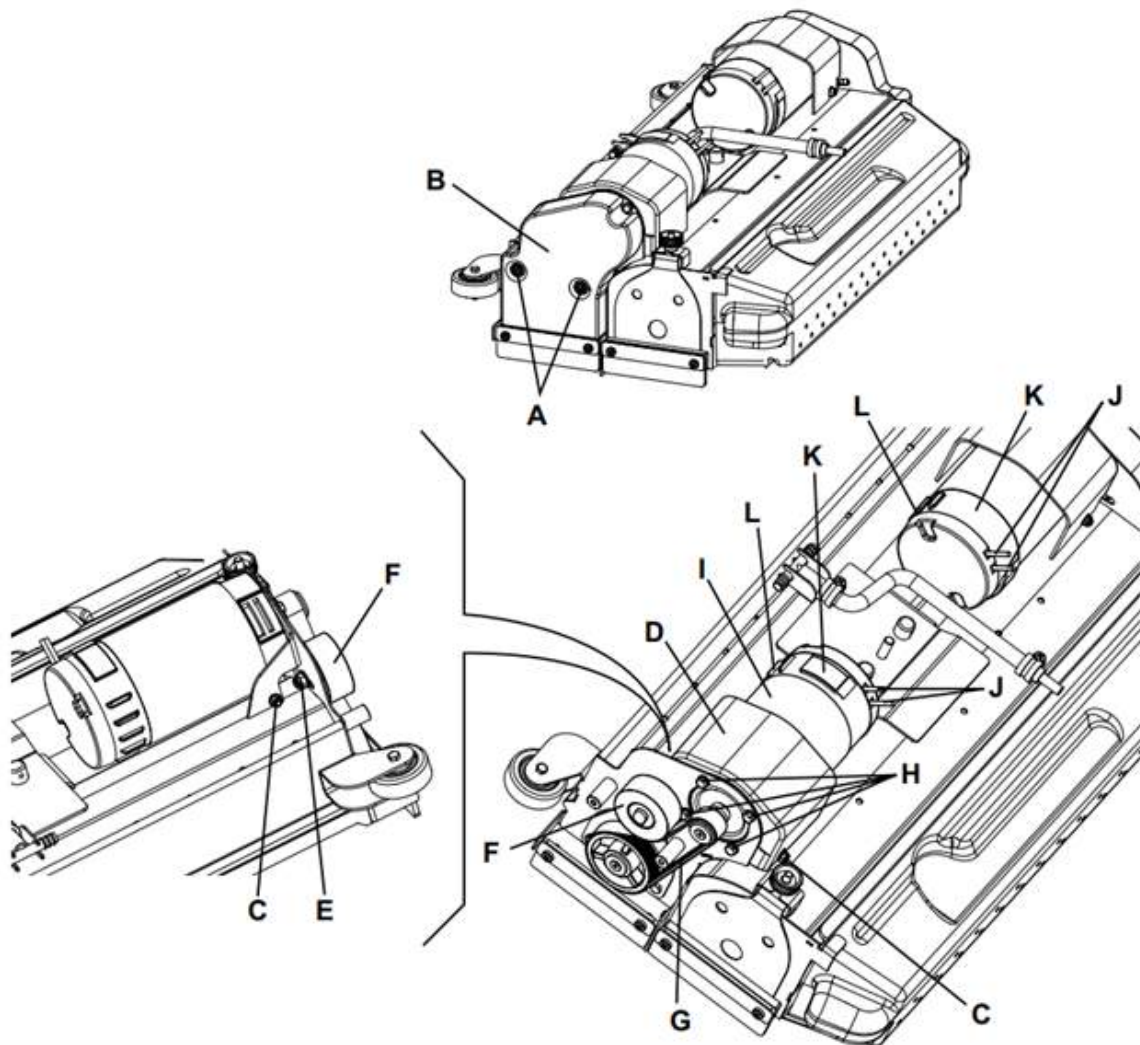

Brush Motor Carbon Brushes for SC650 66D/ 71D

Removal

1. Remove the brush/pad-holder deck (see the procedure in the relevant paragraph).
2. Rotate cover (A) to open it.
3. Use the tool to take out carbon brush seat (B).
4. Check the carbon brushes (C) for wear. Replace the carbon brushes when: the contact with the motor armature is insufficient, the carbon brushes are worn, the carbon brush contact surface is not integral, the thrust spring is broken, etc.

Installation

5. Assemble the components in the reverse order of disassembly.

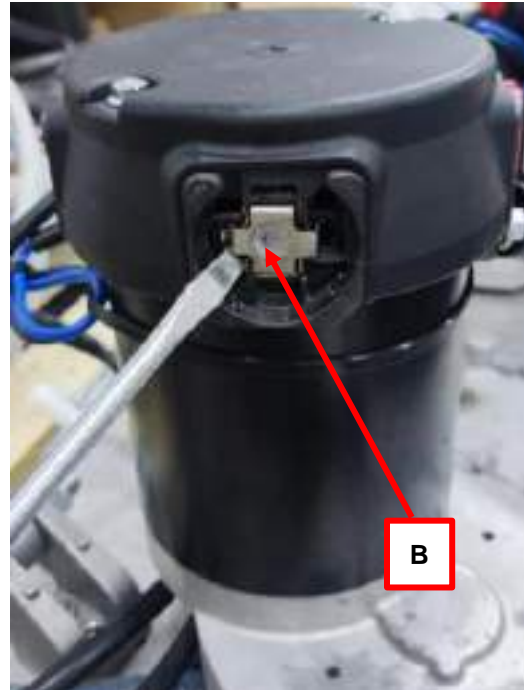

Brush Motor Carbon Brushes for SC650 85D / 71C

Removal

1. Remove the brush motor (see the procedure in the relevant paragraph).
2. At the workbench, remove dust and debris from the motor, especially in the area of the protection clamp (A).
3. Open the rubber buckle (E).
4. Remove the protection clamp (A).
5. For each carbon brush, move the protection (B) and remove the screws (C).
6. Remove the carbon brushes (D).
7. Check the carbon brushes (D) for wear. Replace the carbon brushes when: the contact with the motor armature is insufficient, the carbon brushes are worn, the carbon brush contact surface is not integral, the thrust spring is broken, etc. Replace the carbon brushes as an assembly.

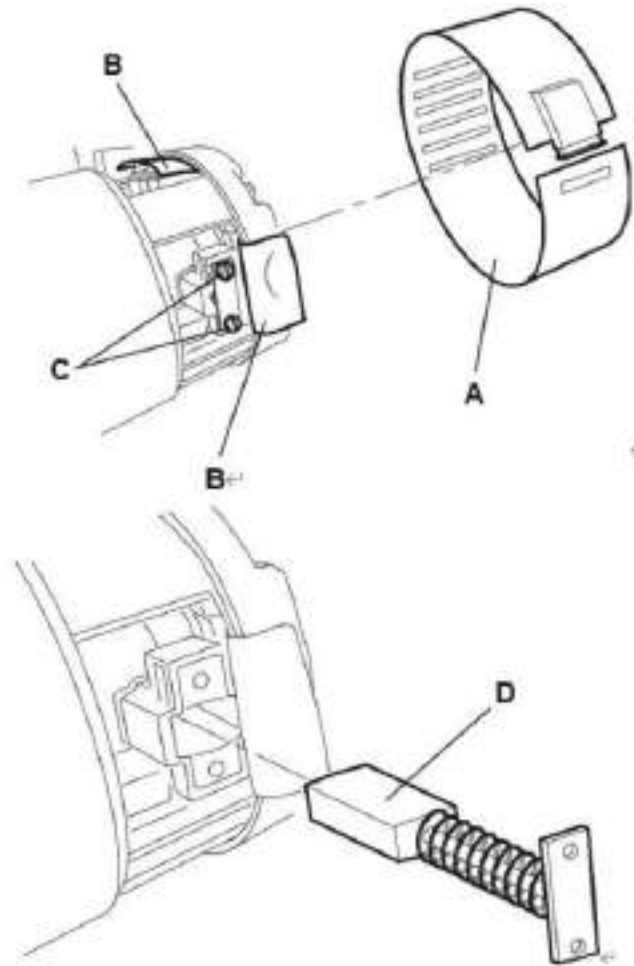

Installation

8. Assemble in the reverse order of disassembly.

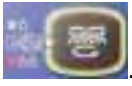
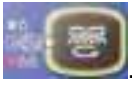

Brush Deck Lifting/Lowering Actuator

Removal

1. Press the power switch on the machine . After the logo "NILFISK" disappears on the screen, input the password by push the "1234" button to reach the menu. 
2. Lower the brush/pad-holder deck by pressing the switch .
3. Drive the machine to the appointed disposal area and empty the recovery tank with the hose.
4. Drive the machine on a level floor.
5. Turn off the machine by pressing and holding the switch  for nearly a second.
6. Disconnect the battery connector.
7. Grasp the handle and carefully lift the recovery tank.
8. Remove the nut (A) and recover the screws and washers.
9. Remove the nut (B) and recover the screws and bushings.
10. Disconnect the connector (C) of the deck lifting/lowering actuator.
11. Remove the actuator (D).

Installation

12. Assemble in the reverse order of disassembly.

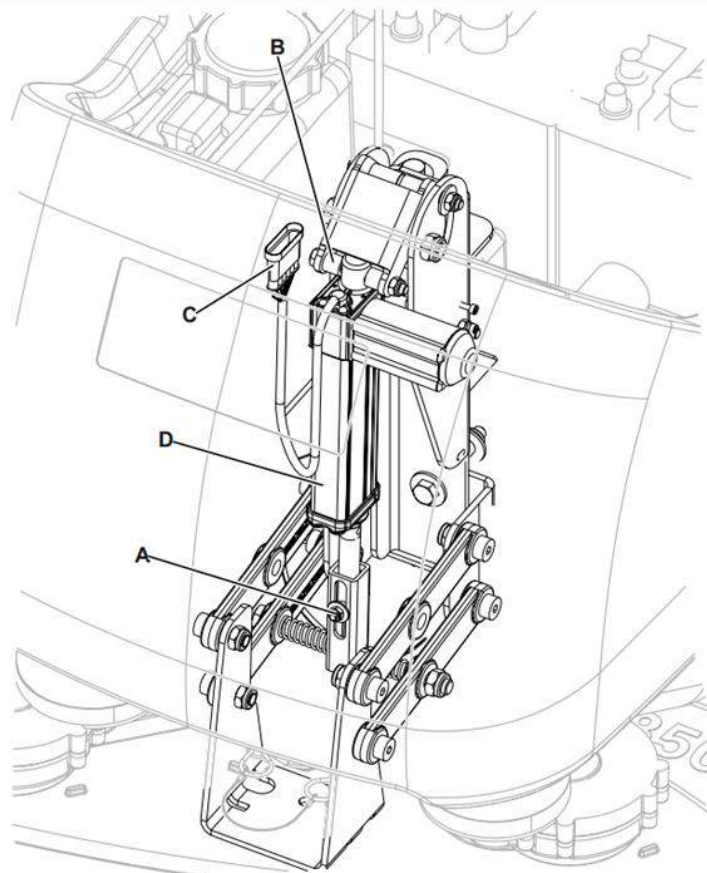

Specifications

| Description / Model | SC650 66D | SC650 71D | SC650 85D | SC650 71C |
|--|------------------|-----------|------------|-----------|
| Cleaning width | 660 mm | 710 mm | 837 mm | 703 mm |
| Brush/pad diameter | 330 mm | 355 mm | 430 mm | N/A |
| Brush pressure with extra-pressure function turned off | 21kg | 22kg | 31kg | 35 kg |
| Brush pressure with extra-pressure function turned on | 32kg | 35kg | 44kg | N/A |
| Brush deck right/left offset | 35/35 mm | 75/75 mm | 132/132 mm | 91/91 mm |
| Brush distance from the floor (when lifted) | 125 mm | | | 60 mm |
| Brush motor power (rated) | 2 x 400 W | | | 2 x 600 W |
| Rotation speed | 220 rpm | | | 613 rpm |
| Actuator technical data | Maximum load | 700 N | | |
| | Maximum speed | 31.3 mm/s | | |
| | Regulated travel | 120 mm | | |
| | Voltage | 24V | | |
| | Protection class | IP 65 | | |
| Actuator normal current draw | In lifting | Max 2.8 A | | |
| | In lowering | Max 1.5 A | | |

38 Squeegee System

Functional Description

The squeegee system cleans the liquid off the floor, which is then collected by the recovery system.

The squeegee is mounted on the squeegee bracket and the weight of the squeegee kit presses it down on the floor.

The squeegee can be lifted and lowered by the operator manually using lever. By lifting the squeegee, the machine can scrub without picking up the water.

In case of fixed obstacles on the floor, the squeegee can be lifted to pass through the obstacles.

The front blade has an opening in the bottom edge so the squeegee can collect the water on the floor. The design and the central duct make it easy for the squeegee to clear the water. The bottom edge of the rear blade is smooth.

Component Locations

- Squeegee lift/lowering lever
- Squeegee bumper wheel
- Squeegee holder
- Mounting handwheels
- Squeegee adjusting handwheel
- Squeegee blades

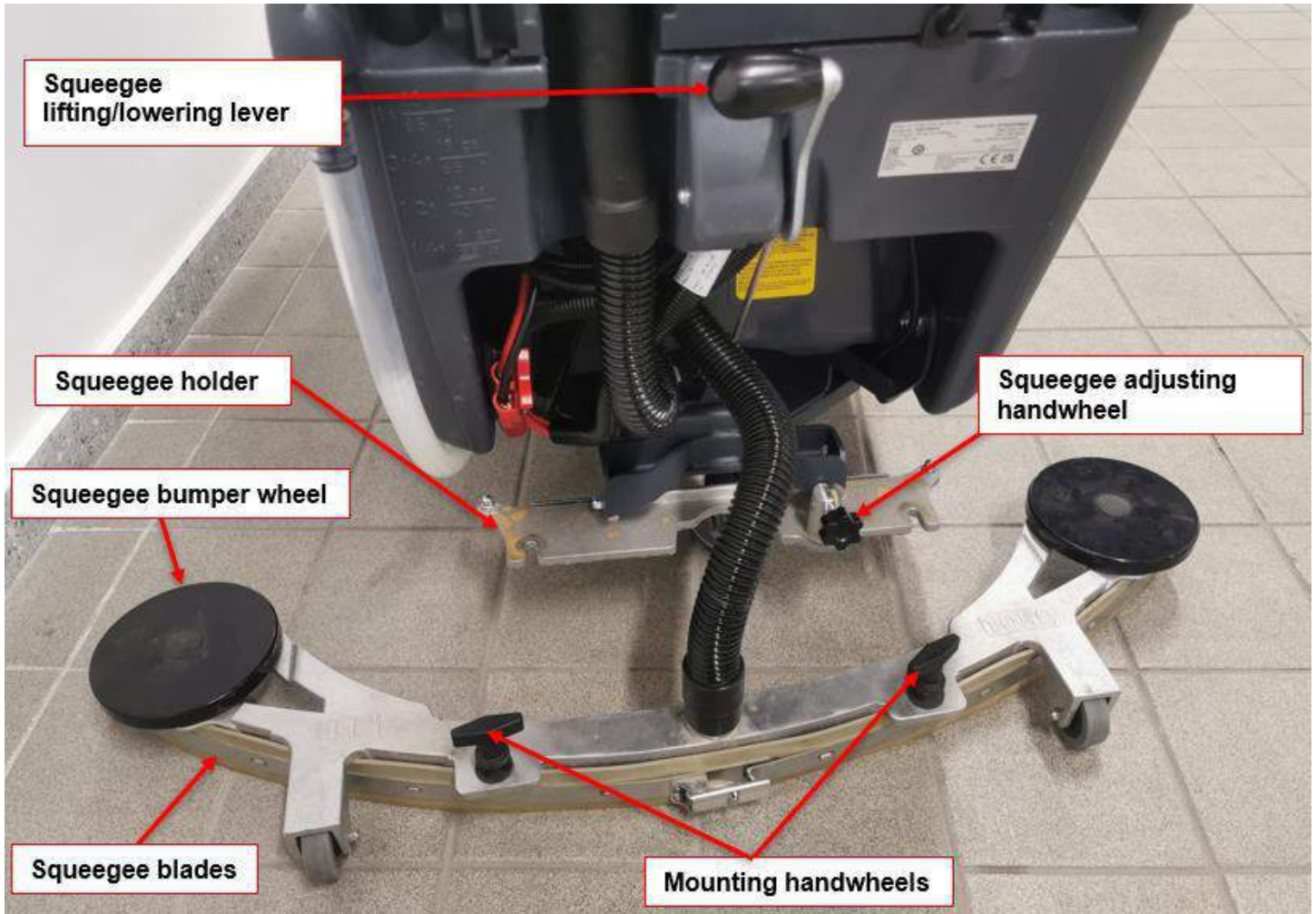

Maintenance and Adjustment

Squeegee cleaning

1. Drive the machine to a level floor.
2. Ensure that the machine is off.
3. Lower the squeegee with the lever.
4. Loosen the handwheels and remove the squeegee.
5. Disconnect the vacuum hose (B) from the squeegee connector (C).
6. Wash and clean the squeegee. Clean the compartments (A) and the hole (B) especially. Check the front blade (C) and the rear blade (D) for integrity, cuts and tears, if necessary replace them.
7. Assemble the squeegee in reverse order of disassembly.

Squeegee blade check and replacement



CAUTION!

It is advisable to wear protective gloves when cleaning the squeegee because there may be sharp debris.

1. Clean the squeegee as shown in the previous paragraph.
2. Check that the edges (E) of the front blade (C) and the edges (F) of the rear blade (D) lay down on the same level, along their length; otherwise adjust their height according to the following procedure:
 - Remove the tie rod (G), disengage the fasteners (M) to adjust the rear blade (D); then engage the fasteners and install the tie rod.
 - Loosen the handwheels (I) and adjust the front blade (C); then tighten the handwheels.
3. Check the front blade (C) and rear blade (D) for integrity, cuts and tears, if necessary replace them as shown below. Check the front corner (J) of the rear blade for wear; if necessary, overturn the blade to replace the worn corner with an integral one. If the other corners are worn too, replace the blade according to the following procedure:
 - Disengage the tie rod (G), disengage the fasteners (M), remove the retaining strip (K) and replace/overturn the rear blade (D). Install the blade in the reverse order of removal.
 - Unscrew the handwheels (I) and remove the retaining strip (L), then replace the front blade (C). Install the blade in the reverse order of removal.

After the blade replacement (or overturning), adjust the height as shown in step 2.

4. Connect the vacuum hose to the squeegee.
5. Install the squeegee and screw down the handwheels.
6. If necessary, adjust the squeegee balance adjusting handwheel (N) so that the rear blade (D) - in all its length - touches the floor.

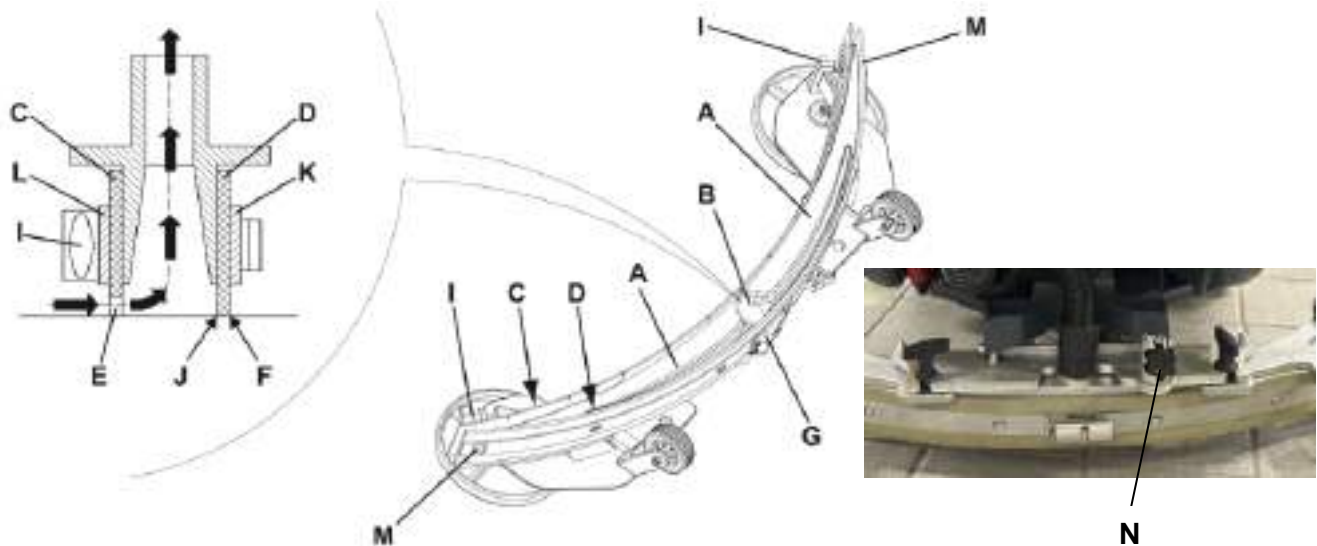

Troubleshooting

| Trouble | Possible causes | Remedy |
|---|--|---|
| The recovery water vacuuming is insufficient or there is no vacuuming | The squeegee is dirty or the squeegee blades are worn or damaged | Clean or repair/replace |
| The squeegee leaves water marks on the floor | There is debris under the squeegee blades | Remove |
| | The squeegee blades are worn, chipped or torn | Replace |
| | Squeegee is not balanced | Adjust the squeegee balance adjusting handwheel |

Removal and Installation

Squeegee assembly

Removal

Follow the squeegee cleaning step 1~5.

Installation

Assemble components in reverse order of assembly.

Specifications

| Description | Unit | Value |
|-----------------------------|-----------|--|
| Machine width with squeegee | mm/Inches | 890 / 35 (SC650 66D/71D/71C) 1040/ 40.9 (SC650 85D) |

40 Recovery System

Functional Description

The recovery system removes the dirty water from the floor and pipes it to a recovery tank. When the machine is running, the dirty water on the floor is collected by the squeegee blades and collected through the slots in the same, piped through the vacuum hose and into the tank by the airflow created by vacuum motor (M2). The dirty water is piped into the recovery tank, while the airflow continues to the vacuum fan.

A tank with a grid collects the largest debris going through the recovery tank hose.

The automatic float in the vacuum grid stops vacuum system motor (M2) from collecting any liquids.

When the automatic float closes and shuts down the vacuum system, the vacuum system motor noise will increase and the floor will not be dried.



The vacuum system is activated automatically with the One-Touch button . It can then be managed



independently via the vacuum button . The vacuum system is activated in full power or silent mode depending on the last mode in use before the machine was switched off. This mode can be changed by repeatedly



pressing the vacuum button . The various vacuum modes are also displayed on the multifunction display. The circuit is protected by the vacuum system motor fuse (F2). When the recovery tank is full it can be emptied through the drain hose.

To work properly, the vacuum motor (M2) needs the following inputs/conditions:

- Vacuum function on
- Battery level not in condition with flashing segment

Wiring Diagram

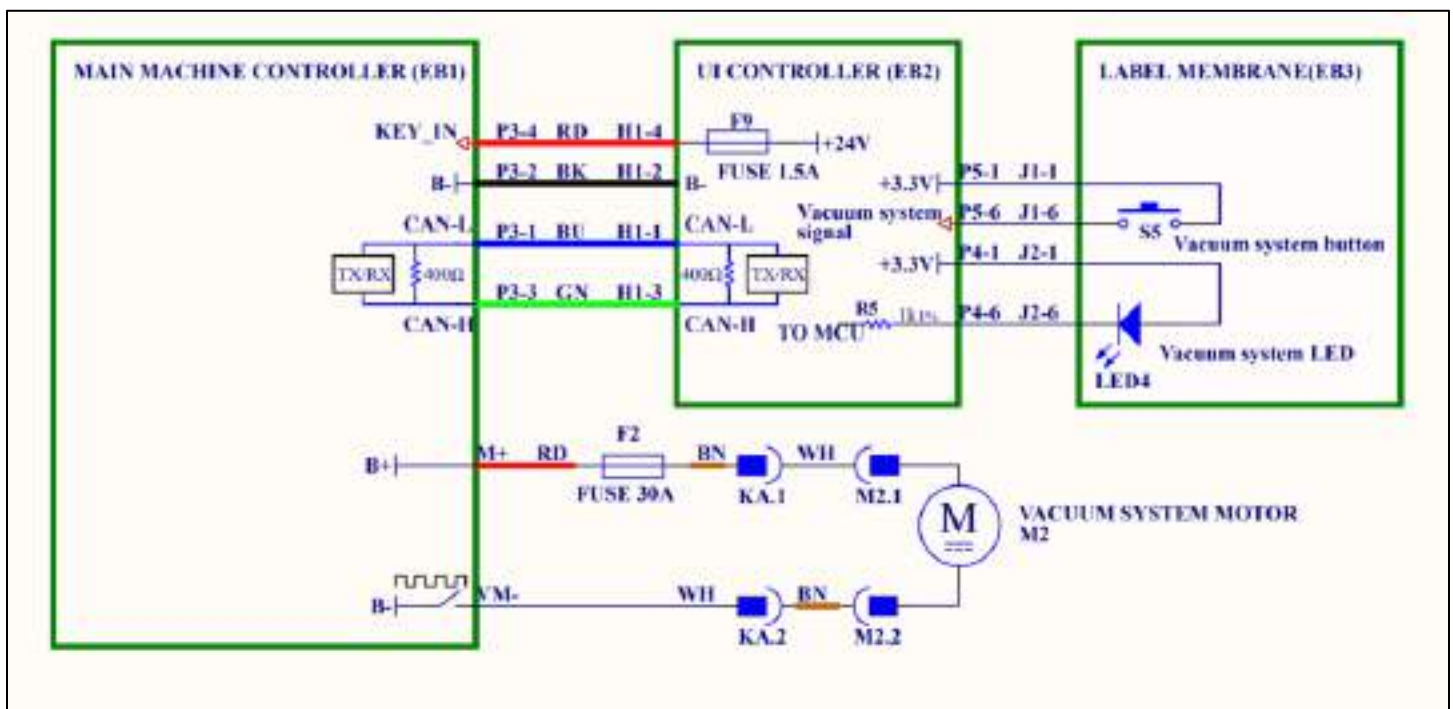

Component Locations

- Recovery tank cover
- Container with debris collection grid
- Vacuum grid with automatic shut-off float
- Recovery water drain hose
- Vacuum motor connecting terminals
- Cover gasket
- Recovery tank
- Squeegee vacuum hose
- Vacuum motor (M2)
- Vacuum motor fuse (F2)



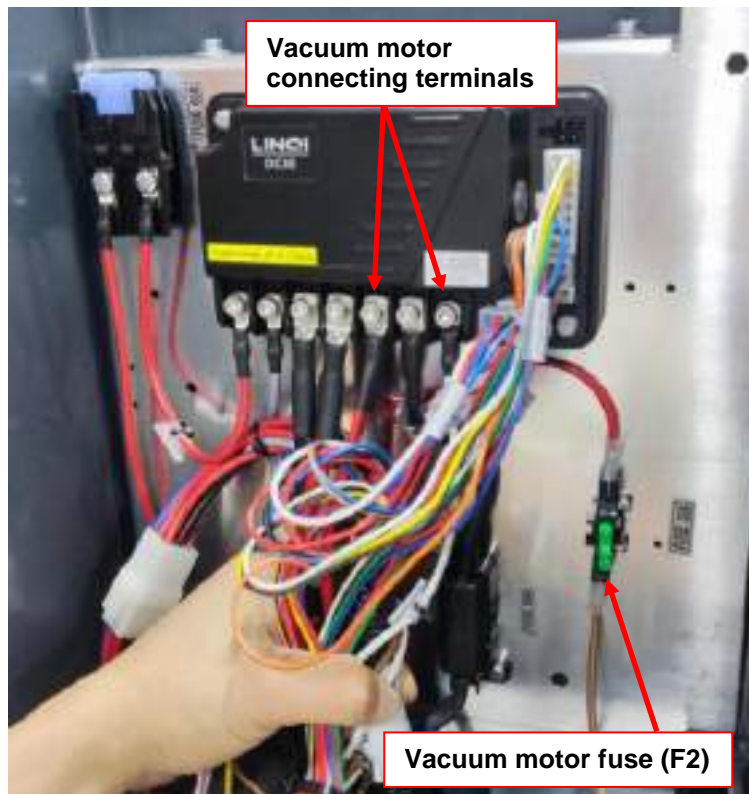
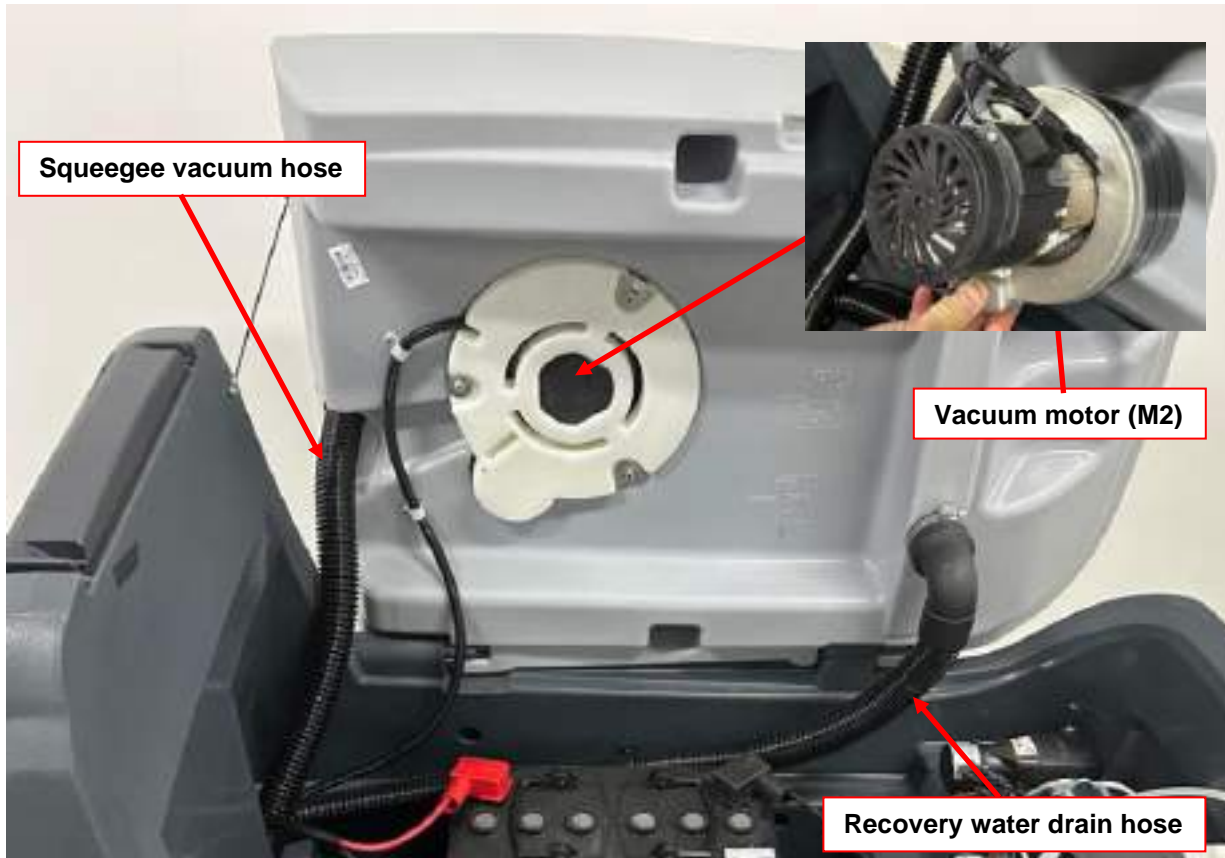

Maintenance and Adjustment

Recovery Tank Cleaning

1. Drive the machine to the appointed disposal area.
2. Turn off the machine by pressing and holding the switch for nearly a second.
3. Open the cover (A).
4. Drain the water from the tanks with the hoses.
5. Wash with clean water the cover (A), the tanks (B and C) and the vacuum grid with automatic shut-off float (D). If necessary, release the fasteners (E) and open the grid (D), recover the float (F), clean all the components and then reinstall them.
6. Remove and clean the debris tray (M).
7. Check the tank cover gasket (G) for integrity.



NOTE

The gasket (G) creates vacuum in the tank that is necessary for vacuuming the recovery water.

If necessary replace the gasket (G) by removing it from its housing (H). When assembling the new gasket, install the joint (I) in the rear central area, as shown in the figure.

8. Check that the seating surface (J) of the gasket (G) is integral and adequate for the gasket itself.



NOTE

The hole (K), allowing to compensate the air in the cover air gap, contributes to create vacuum in the tank.

9. Close the cover (A).

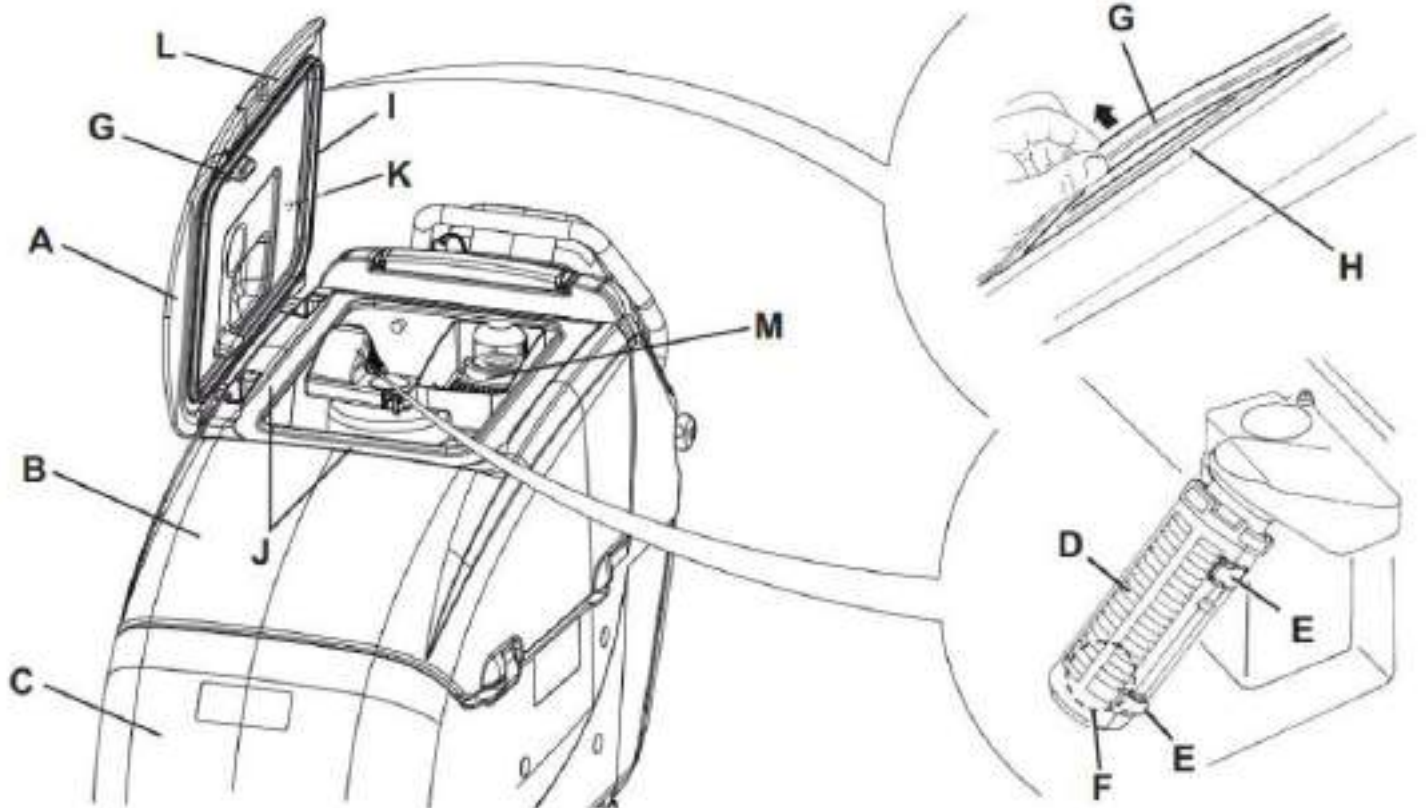

Vacuum Motor Current Draw Test



Warning! This procedure must be performed by qualified personnel only.

1. Apply the amp clamp (A) to one of the vacuum motor wires (B).
 2. Press power switch to turn on the machine.
 3. Check if the current draw of vacuum motor is between 11A and 18A at 24V.
 4. If the amperage is higher than 18A, perform following procedures to detect and correct the abnormal amperage:
 - Remove vacuum motor and check the condition of all its components, repair or replace them if necessary.
- If above-mentioned procedures can't lead to correct amperage, the vacuum motor must be replaced.

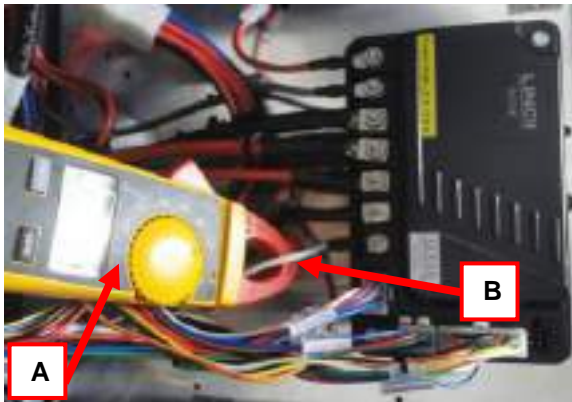

Vacuum Motor Carbon Brush Check/Replacement (All models)

1. Remove the vacuum motor(see the vacuum motor removal procedure).
2. At the workbench, remove the cover (A) (press-fitted) from the vacuum motor (B).
3. Remove the screws (C).
4. Disconnect the electrical connections (D).
5. Remove the carbon brushes (E).
6. Check the carbon brushes for wear. Replace the carbon brushes when: the contact with the motor armature is insufficient, the carbon brushes are worn, the carbon brush contact surface is not integral, the thrust spring is broken, etc.
7. If necessary, replace the carbon brushes. Replace the carbon brushes as an assembly.
8. Assemble in the reverse order of disassembly.

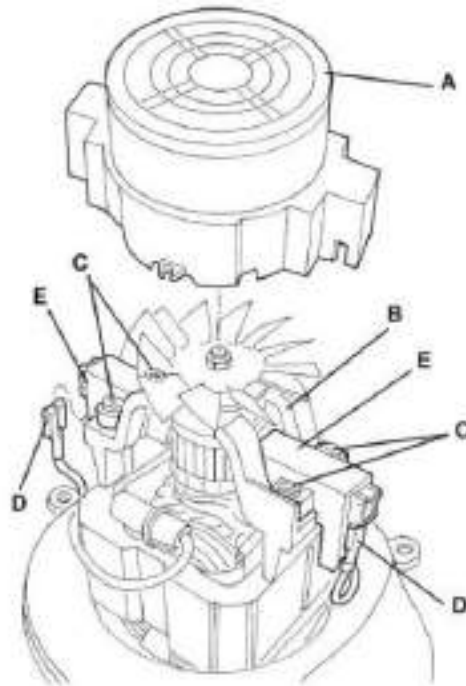

Troubleshooting

| Trouble | Possible causes | Remedy |
|--|--|---|
| The vacuum motor will not turn on | Wiring between Main machine controller (EB1) | Repair |
| | Label membrane (EB3) faulty | Replace |
| | Vacuum motor fuse is open | Replace |
| | Vacuum motor faulty | Check the amperage |
| | A failed driver in the Main machine controller (EB1) | Replace the Main machine controller (EB1) |
| Suction of dirty water is insufficient or non-existent | Activation of automatic float shut-off | Drain the recovery tank |
| | Debris collection filter dirty | Clean |
| | Vacuum grid with automatic float shut-off dirty | Clean |
| | Tank cover not correctly positioned | Adjust |
| | Tank cover seal damaged or not working correctly | Clean or replace |
| | Vacuum motor container dirty | Clean |
| | Vacuum seals damaged or not working correctly | Repair or replace |

Removal and Installation

Vacuum Motor (M2)

Removal

1. If the recovery tank contains recovery water:
 - Drive the machine to the appointed recovery water disposal area.
 - Turn off the machine by pressing and holding the switch for nearly a second.
 - Empty the recovery tank with the hose.
2. Drive the machine on a level floor.
3. Turn off the machine by pressing and holding the switch for nearly a second.
4. Disconnect the battery connector.
5. Lift the recovery tank.
6. Remove 3 screws (A),
7. Remove the vacuum motor cover (B) and filter (C).
8. Take out the vacuum motor (D) along with the sound-deadening foams (E) / (F) and rubber gaskets (G) / (H).
9. Disconnect the electrical connection (I) of the vacuum motor.
10. Check the efficiency of the gasket (G), if necessary, replace it.

Installation

Assemble components in reverse order of disassembly, and note the following:

- If necessary, clean the filter (C) before assembling it (see the procedure in the relevant paragraph).

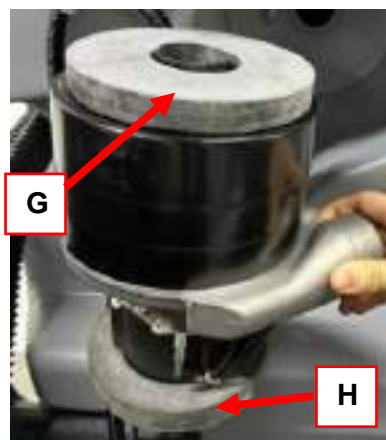
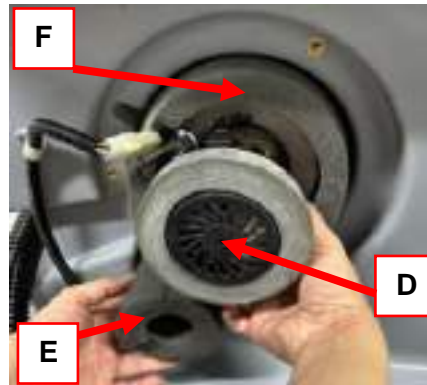
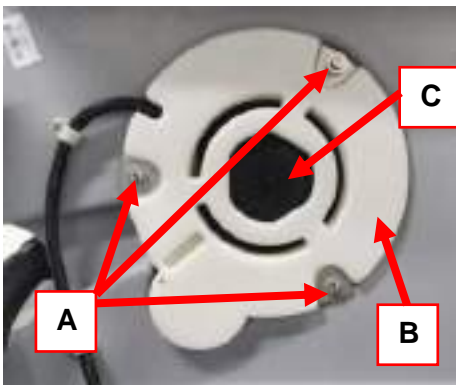

Specifications

| Description | Unit | Value |
|------------------------------------|--------|-----------|
| Recovery tank capacity | L/Gal. | 80 / 21.1 |
| Vacuum motor technical data | W | 400 |
| | V DC | 24 |
| Vacuum capacity (normal mode) | Kpa | 12.2 |
| Vacuum capacity (ECO mode) | Kpa | 9.1 |
| Vacuum motor current (normal mode) | A | ≈17@24V |
| Vacuum motor current (silent mode) | A | ≈15@20V |